



Accessori standard in ottone



Brass standard accessories



Standardverschraubungen Messing



Accessoires standard laiton



Accesorios estándar en latón

AS51



AS51OR



AS52K



AS53



AS54K



AS54



AS54OR



AS54S



AS54P



AS55K



AS55



AS55OR



AS56



AS57



AS57OR-E



AS57OR



AS57K



AS57B



AS58



AS79



AS79K



AS59



AS60K



AS60



AS61



AS62K



AS63K



AS64



AS65K



AS66K



AS67K



AS68K



AS69D



AS69



AS69K



AS69OR



AS69KL



AS93KL



AS94KL



AS95KL



AS96KL



AS97F



AS98F



AS70K



AS71K



AS72



AS73



AS75K



AS76





Accessori standard in ottone



Brass standard accessories



Standardverschraubungen Messing



Accessoires standard laiton



Accesorios estándar en latón

AS77



AS80K



AS81K



AS82K



AS83KG



AS83G



AS87



AS88



AS87OR



AS88OR



AS91



AS92N



Dati tecnici degli accessori standard in ottone



Brass standard accessories technical data



Technischen Daten der Standardverschraubungen Messing



Données techniques des accessoires standard en laiton



Datos técnicos de los accesorios estándar en latón



Caratteristiche principali

1. Gamma completa M5 - 1"
2. Filettatura BSPP cilindrica UNI-ISO228 (con O-Ring), BSPT conica UNI-ISO 7 teflonata, Metrica ISO/R 262
3. Guarnizione in NBR Silicon free
4. Compatibilità numerosi fluidi industriali
5. Vasta gamma
6. Robustezza meccanica



Main features

1. Complete Range M5 - 1"
2. Threading BSPP cylindrical UNI-ISO228 (with O-Ring), BSPT conical teflon-coated UNI-ISO 7, ISO/R 262 metric
3. Silicon free NBR seal
4. All Fluids compatible
5. Wide range
6. Mechanical Resistance



Hauptmerkmale

1. Vollständiges Sortiment M5 - 1"
2. BSPP zylindrisches Gewinde UNI-ISO228 (mit O-Ring), teflonbeschichtet UNI-ISO 7 BSPT, metrische ISO/R 262
3. Silikonfreie NBR-Dichtung
4. Kompatibel mit allen Medien
5. Große Auswahl
6. Mechanische Festigkeit



Principales caractéristiques

1. Gamme complète M5 - 1"
2. Filetage BSPP cylindrique UNI-ISO228 (avec joint torique), BSPT conique UNI-ISO 7 avec téflon, ISO/R 262 métrique
3. Garniture NBR sans silicone
4. Tous fluides compatibles
5. Large gamme
6. Résistance mécanique



Características principales

1. Gama completa M5-1"
2. Roscado BSPP cilíndrica UNI-ISO228 (con junta tórica), BSPT cónica UNI-ISO 7 con teflón, métrica ISO/R 262
3. Guarnición en NBR sin silicona
4. Compatibilidad con numerosos fluidos industriales
5. Amplia gama
6. Robustez mecánica



Applicazioni

1. Aria Compressa
2. Impianti per automazione pneumatica
3. Gas inerti, vapore, fluidi
4. Circuiti acqua industriale
5. Vuoto



Applications

1. Compressed Air
2. Systems for pneumatic automation
3. Inert Gases, Fluids, Steam
4. Industrial water circuits
5. Vacuum



Anwendungen

1. Druckluft
2. Systeme für die pneumatische Automatisierung
3. Inertgase, Flüssigkeiten, Dampf
4. Industrielle Wasserkreisläufe
5. Leer



Applications

1. Air comprimé
2. Installations pour l'automatisation pneumatique
3. Gaz neutres, vapeur
4. Circuits d'eau industrielle
5. Vide



Aplicaciones

1. Aire comprimido
2. Instalaciones para automación neumática
3. Gases inertes, vapor, fluidos
4. Circuitos de agua industrial
5. Vacío

Materiali

Corpo: Ottone nichelato CW614N / CW617N

Matériels

Corps: Laiton nickelé CW614N / CW617N

Materials





Body: Nickel plated brass CW614N / CW617N

Materiales

Cuerpo: Latón niquelado CW614N / CW617N

Werkstoffen

Körper: vernickelt Messing
CW614N/CW617N

 Pressione e temperatura	 Pressure and Temperature	 Druck und Temperatur	 Pression et Température	 Presión y Temperatura
Filetti - Threads - Gewinde - Filets - Roscas		Pressione massima - Maximum pressure <i>Maximum druck - Pression maximale - Presión máxima</i>		
1/8		150 bar		
1/4		100 bar		
3/8		75 bar		
1/2		50 bar		
3/4		85 bar		
1"		80 bar		
Temperatura: 0°C / +70°C	Temperature: +32°F / +158°F	Temperatur: 0°C / +70°C	Température: 0°C / +70°C	Temperatura: 0°C / +70°C

Fluido

Acqua, olio, aria compressa

Fluid

Water, oils, compressed air

Fluid

Wasser, oel, druckluft

Fluide

Eau, huile, air comprimé

Fluido

Agua, aceite, aire comprimido

Filettatura

BSPP cilindrica UNI-ISO228 (con O-Ring).
BSPT conica UNI-ISO 7 teflonata.
Metrica ISO/R 262.

Thread types

BSPP parallel UNI-ISO228 (with O-Ring).
BSPT taper UNI-ISO 7 with teflon.
Metric ISO/R 262.

Gewinde

BSPP zylindrisch UNI-ISO228 (mit O-Ring).
BSPT konische UNI-ISO 7 mit Teflon.
Metrische ISO/R 262.

Filetage

BSPP cylindrique UNI-ISO228 (avec joint torique).
BSPT conique UNI-ISO7 teflonée.
Métrique ISO/R 262.

Roscado

BSPP cilíndrico UNI-ISO 228 (con junta tórica).
Teflón con recubrimiento BSPT UNI-ISO 7.
ISO/R 262 métrica.

Filetti

Filettature da M5 a 1"

Threads

Threads from M5 to 1"

Gewinde

Gewinde von M5 bis 1"

Filets

Filetages de M5 à 1"

Roscas

Roscas de M5 a 1"

Norma di riferimento

Norme de référence

Reference standard





Normativa de referencia

Entspricht der Norm

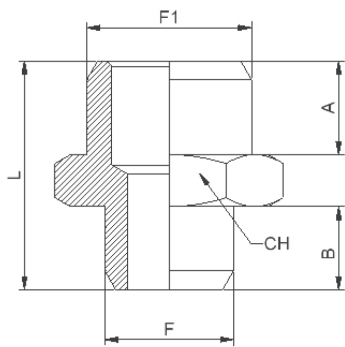

AS 51





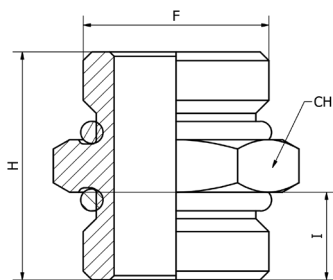

-  **Nipplo cilindrico BSPP metrico**
-  **Nipple parallel BSPP-metric**
-  **Nippel zylindrisches-metrisches Gewinde**
-  **Mamelon cylindrique BSPP- métrique**
-  **Machón cilindrico BSPP- métrico**

CODICE/CODE	F"	F1"	A	B	L	CH	PEZZI/PIECES
AS51M5M5	M5	M5	4	4	11	8	10
AS51M518	M5	G1/8	6	5	15,5	14	10
AS511818	G1/8	G1/8	6	6	16,5	14	10
AS511814	G1/8	G1/4	8	6	18,5	17	10
AS511838	G1/8	G3/8	9	6	20	19	10
AS511812	G1/8	G1/2	12	6,5	25	22	10
AS511414	G1/4	G1/4	8	8	20,5	17	10
AS511438	G1/4	G3/8	9	8	22	19	10
AS511412	G1/4	G1/2	10	8	23	24	10
AS513838	G3/8	G3/8	9	9	23	19	10
AS513812	G3/8	G1/2	10	9	24	24	10
AS513834	G3/8	G3/4	11	9	25,5	30	10
AS511212	G1/2	G1/2	10	10	25,5	24	10
AS511234	G1/2	G3/4	11	10	26,5	30	10
AS511201	G1/2	G1	10	13	29	36	10
AS513434	G3/4	G3/4	11	11	27,5	30	10
AS513401	G3/4	G1	13	11	30	36	10
AS510101	G1	G1	13	13	32	36	10

AS 51OR





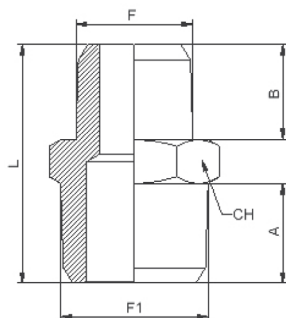

-  **Nipplo cilindrico BSPP con O-ring**
-  **Nipple parallel BSPP with O-ring**
-  **Nippel zylindrisches Gewinde mit O-ring**
-  **Mamelon cylindrique BSPP, o-ring**
-  **Machón cilindrico BSPP con o-ring**

CODICE/CODE	F"	F1"	I	I1	H	CH	PEZZI/PIECES
AS51OR18	G1/8	-	-	6,5	17,5	14	10
AS51OR14	G1/4	-	-	8	21	17	10
AS51OR38	G3/8	-	-	9	23	20	10
AS51OR12	G1/2	-	-	10	26	24	10
AS51OR1814	G1/8	G1/4	6,5	8	19,5	17	10
AS51OR1838	G1/8	G3/8	6,5	9	21	20	10
AS51OR1438	G1/4	G3/8	8	9	22	20	10
AS51OR1412	G1/4	G1/2	8	10	24	24	10
AS51OR3812	G3/8	G1/2	9	10	25	24	10

AS 52K





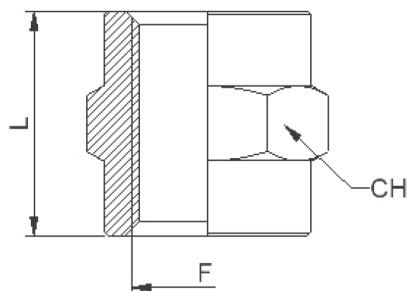

-  **Nipplo conico BSPT**
-  **Nipple taper BSPT**
-  **Nippel konisches Gewinde**
-  **Mamelon conique BSPT**
-  **Machón cónico BSPT**

CODICE/CODE	F"	F1"	A	B	L	CH	PEZZI/PIECES
AS52K1818	R1/8	R1/8	8	8	20,5	12	10
AS52K1814	R1/8	R1/4	11	7,5	23	14	10
AS52K1838	R1/8	R3/8	11	7,5	23,5	17	10
AS52K1414	R1/4	R1/4	11	11	27	14	10
AS52K1438	R1/4	R3/8	11	10,5	26,5	17	10
AS52K1412	R1/4	R1/2	12,5	10,5	28,5	22	10
AS52K3838	R3/8	R3/8	11	11	27	17	10
AS52K3812	R3/8	R1/2	14	11,5	31	22	10
AS52K1212	R1/2	R1/2	13,5	13,5	33	22	10
AS52K1234	R1/2	R3/4	14	12,5	32,5	27	10
AS52K3434	R3/4	R3/4	14	14	34,5	27	10
AS52K3401	R3/4	R1	15,5	13	35,5	34	10
AS52K0101	R1	R1	15,5	15,5	37	34	10

AS 53





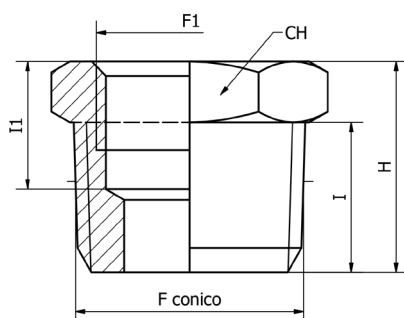

-  **Manicotto cilindrico BSPP - metrico**
-  Sleeve parallel BSPP - metric
-  Muffe zylindrisches-konisches Gewinde
-  Manchon cylindrique BSPP- métrique
-  Manguito cilindrico BSPP- métrico

CODICE/CODE	F"	L	CH	PEZZI/PIECES
AS53M5M5	M5	11	8	10
AS531818	G1/8	15	14	10
AS531414	G1/4	22	17	10
AS533838	G3/8	23	22	10
AS531212	G1/2	28,5	26	10
AS533434	G3/4	32	32	10
AS530101	G1	31	38	10

AS 54K





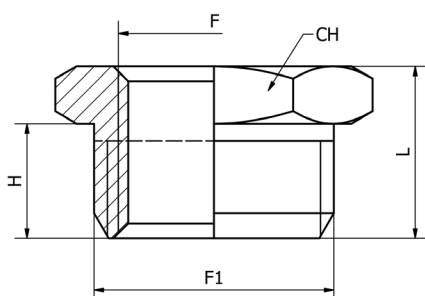

-  **Riduzione femmina cilindrico - maschio conico BSPT**
-  Reducer female cylindrical - male taper BSPT
-  Reduzierung konisches Gewinde
-  Réduction, femelle cylindrique - mâle conique BSPT
-  Reducción hembra cilíndrica - macho cónico BSPT

CODICE/CODE	F"	F1"	I	I1	H	CH	PEZZI/PIECES
AS54K1418	R1/4	G1/8	11	9,5	15,5	14	10
AS54K3818	R3/8	G1/8	11	9	16	17	10
AS54K3814	R3/8	G1/4	11	11,5	16	17	10
AS54K1218	R1/2	G1/8	12,5	10	18	22	10
AS54K1214	R1/2	G1/4	12,5	11,5	18	22	10
AS54K1238	R1/2	G3/8	12,5	11,5	18	22	10
AS54K3438	R3/4	G3/8	14	12	20	27	10
AS54K3412	R3/4	G1/2	14	14	20	27	10
AS54K0138	R1	G3/8	15,5	13	21,5	34	10
AS54K0112	R1	G1/2	15,5	14	21,5	34	10
AS54K0134	R1	G3/4	15,5	14	21,5	34	10

AS 54



-  **Riduzione maschio-femmina cilindrica BSPP-metrico**
-  Reducer male-female parallel BSPP-metric
-  Reduzierung zylindrisches Gewinde
-  Réduction, mâle-femelle cylindrique BSPP- métrique
-  Reducción macho-hembra cilíndrica BSPP- métrico

CODICE/CODE	F1"	F"	H	L	CH	PEZZI/PIECES
AS5418M5	G1/8	M5	6,5	10,5	14	10
AS541418	G1/4	G1/8	8	12,5	17	10
AS543818	G3/8	G1/8	9	14	19	10
AS543814	G3/8	G1/4	9	14	19	10
AS541218	G1/2	G1/8	10	15	24	10
AS541214	G1/2	G1/4	10	15	24	10
AS541238	G1/2	G3/8	10	15	24	10
AS543414	G3/4	G1/4	11	16,5	30	10
AS543438	G3/4	G3/8	11	16,5	30	10
AS543412	G3/4	G1/2	13,5	19,5	30	10
AS540138	G1	G3/8	13,5	19,5	36	10
AS540112	G1	G1/2	13	19	36	10
AS540134	G1	G3/4	13	19	36	10

AS 54OR

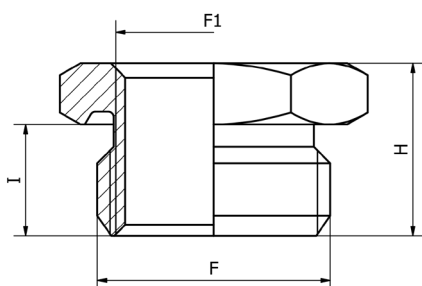

Riduzione maschio-femmina cilindrica BSPP-metrico con O-ring

Reducer male-female parallel BSPP metric with O-ring

Reduzierung zylindrisches Gewinde mit O-ring

Réduction, mâle-femelle cylindrique BSPP- métrique avec o-ring

Reducción macho-hembra cilíndrica BSPP- métrico con o-ring

CODICE/CODE	F"	F1"	I	H	CH	PEZZI/PIECES
AS54OR18M5	G1/8	M5	6,5	11	14	10
AS54OR1418	G1/4	G1/8	8	13	19	10
AS54OR3818	G3/8	G1/8	9	14	20	10
AS54OR3814	G3/8	G1/4	9	14	20	10
AS54OR1218	G1/2	G1/8	10	15,5	24	10
AS54OR1214	G1/2	G1/4	10	15,5	24	10
AS54OR1238	G1/2	G3/8	10	15,5	26	10

AS 54S

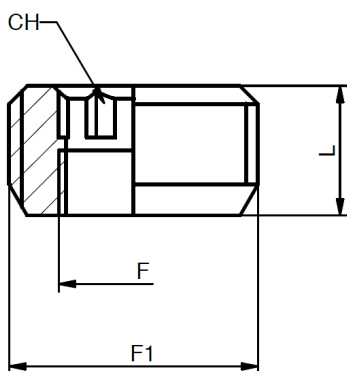

Riduzione a scomparsa a brugola cilindrica BSPP-metrico

Hexagonal hidden reducer parallel BSPP-metric

Reduzierung zylindrisches Gewinde

Réduction, cylindrique, hexagonal BSPP- métrique

Reducción cilíndrica, hexagonal BSPP- métrico

CODICE/CODE	F"	F1"	L	CH	PEZZI/PIECES
AS54S18M5	M5	G1/8	8	3	10
AS54S1418	G1/8	G1/4	9	6	10
AS54S3818	G1/8	G3/8	9	6	10
AS54S3814	G1/4	G3/8	9	8	10
AS54S1214	G1/4	G1/2	10,5	10	10
AS54S1238	G3/8	G1/2	10,5	10	10
AS54S3412	G1/2	G3/4	13	12	10
AS54S0134	G3/4	G1	15	17	10

AS 54P

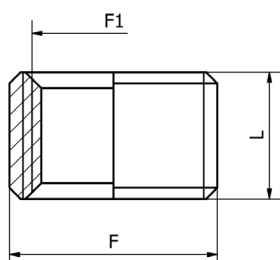

Riduzione a scomparsa passante cilindrica BSPP-metrico

Hidden reducer parallel BSPP-metric

Reduzierung zylindrisches Gewinde

Réduction, cylindrique BSPP- métrique

Reducción cilíndrica BSPP- métrico

CODICE/CODE	F"	F1"	L	PEZZI/PIECES
AS54P1418	G1/4	G1/8	8	10
AS54P3814	G3/8	G1/4	9	10
AS54P1238	G1/2	G3/8	9,5	10
AS54P3412	G3/4	G1/2	10	10
AS54P0134	G1	G3/4	12	10
AS54P4101	G 1" 1/4	G1	12	10

AS 55K

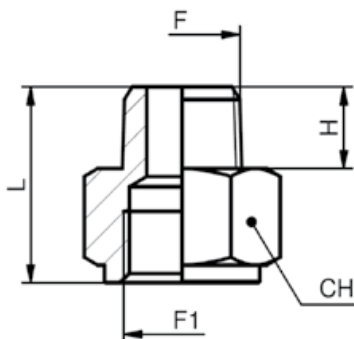

Maggiorazione femmina cilindrico - maschio conico BSPT

Extension female cylindrical - male taper BSPT

Verlängerung konisches Gewinde

Augmentation femelle cylindrique - mâle conique BSPT

Alargue hembra cilíndrica - macho cónico BSPT

CODICE/CODE	F"	F1"	H	L	CH	PEZZI/PIECES
AS55K1818	R1/8	G1/8	7,5	18,5	14	10
AS55K1814	R1/8	G1/4	7,5	21	17	10
AS55K1838	R1/8	G3/8	7,5	21,5	22	10
AS55K1414	R1/4	G1/4	10,5	24	17	10
AS55K1438	R1/4	G3/8	10,5	24,5	22	10
AS55K1412	R1/4	G1/2	10,5	27,5	27	10
AS55K3838	R3/8	G3/8	10,5	24,5	22	10
AS55K3812	R3/8	G1/2	11,5	29,5	24	10
AS55K3834	R3/8	G3/4	11	28	32	10
AS55K1212	R1/2	G1/2	12,5	28,5	27	10
AS55K1234	R1/2	G3/4	14	35	32	10
AS55K1201	R1/2	G1	13	31	38	10
AS55K3434	R3/4	G3/4	13	30	32	10
AS55K3401	R3/4	G1	13	31	38	10
AS55K0101	R1	G1	15,5	33,5	38	10

AS 55

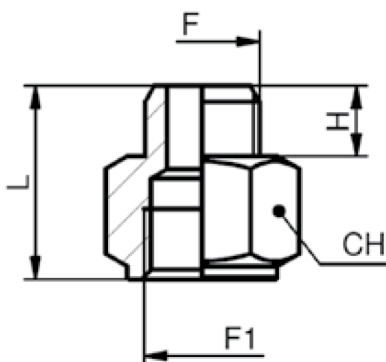

Maggiorazione maschio-femmina cilindrica BSPP-metrico

Extension male-female parallel BSPP-metric

Verlängerung zylindrisches Gewinde

Augmentation mâle-femelle cylindrique BSPP-métrique

Alargue macho-hembra cilíndrica BSPP-métrico

CODICE/CODE	F"	F1"	H	L	CH	PEZZI/PIECES
AS55M518	M5	G1/8	5	16	14	10
AS551818	G1/8	G1/8	6,5	17,5	14	10
AS551814	G1/8	G1/4	6	20	17	10
AS551838	G1/8	G3/8	6,5	20,5	22	10
AS551812	G1/8	G1/2	6,5	23,7	25	10
AS551414	G1/4	G1/4	8	22	17	10
AS551438	G1/4	G3/8	8	22	22	10
AS551412	G1/4	G1/2	9	26	24	10
AS553838	G3/8	G3/8	9	23	22	10
AS553812	G3/8	G1/2	9	26	27	10
AS553834	G3/8	G3/4	9	26	32	10
AS551212	G1/2	G1/2	10	26	27	10
AS551234	G1/2	G3/4	10,5	27,5	32	10
AS551201	G1/2	G1	11	29	38	10
AS553434	G3/4	G3/4	11	27	32	10
AS553401	G3/4	G1	11	29	38	10
AS550101	G1	G1	13	31	38	10

AS 55OR

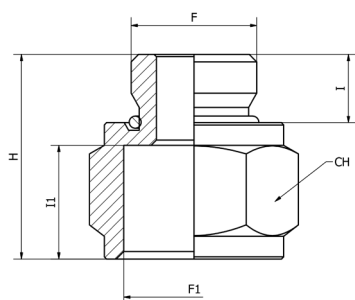

Maggiorazione maschio-femmina cilindrica BSPP con O-ring

Extension male-female parallel BSPP with O-ring

Verlängerung zylindrisches Gewinde mit O-ring

Augmentation mâle-femelle cylindrique BSPP avec o-ring

Alargue macho-hembra cilíndrica BSPP con o-ring

CODICE/CODE	F"	F1"	I	I1	H	CH	PEZZI/PIECES
AS55OR1818	G1/8	G1/8	6,5	8,5	17	14	10
AS55OR1814	G1/8	G1/4	6,5	11	20	17	10
AS55OR1838	G1/8	G3/8	6,5	11,5	21	22	10
AS55OR1414	G1/4	G1/4	8	11	21,5	17	10
AS55OR1438	G1/4	G3/8	8	11,5	22,5	22	10
AS55OR1412	G1/4	G1/2	9	14	26	24	10
AS55OR3838	G3/8	G3/8	9	11,5	23,5	22	10
AS55OR3812	G3/8	G1/2	9	14	27	24	10

AS 56

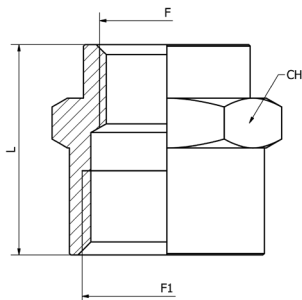

- Manicotto ridotto cilindrico BSPP-metrico**
- Reducing sleeve parallel BSPP-metric
- Muffe Reduziert
- Manchon inégal cylindrique, BSPP-métrique
- Manguito de reducción cilíndrico, BSPP-métrico

CODICE/CODE	F"	F1"	L	CH	PEZZI/PIECES
AS56M518	M5	G1/8	13,5	14	10
AS561814	G1/8	G1/4	18,5	17	10
AS561838	G1/8	G3/8	20	22	10
AS561812	G1/8	G1/2	24	24	10
AS561438	G1/4	G3/8	23	22	10
AS561412	G1/4	G1/2	26	24	10
AS563812	G3/8	G1/2	26	24	10
AS563834	G3/8	G3/4	25	32	10
AS563412	G1/2	G3/4	25	32	10
AS560112	G1/2	G1	25	38	10
AS560134	G3/4	G1	25	38	10

AS 57

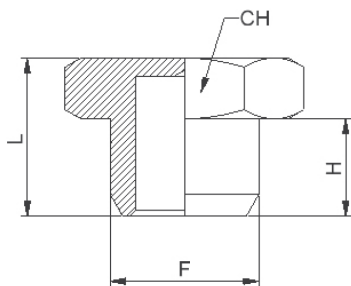

- Tappo esagonale (senza O-ring) cilindrico BSPP-metrico**
- Hexagonal male plug (without O-ring) parallel BSPP-metric
- Stopfen zylindrisches-metrisches Gewinde ohne O-ring
- Bouchon à 6 pans mâle, cylindrique, BSPP-métrique
- Tapón macho cilíndrico, BSPP-métrico

CODICE/CODE	F"	H	L	CH	PEZZI/PIECES
AS5700M5	M5	4	7	8	10
AS570018	G1/8	6,5	10,5	14	10
AS570014	G1/4	8	12,5	17	10
AS570038	G3/8	9	13,5	19	10
AS570012	G1/2	10	15	24	10
AS570034	G3/4	11	16,5	30	10
AS570001	G1	12,5	18,5	38	10

AS 57OR-E

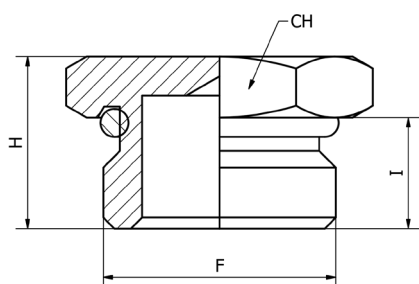

- Tappo esagonale cilindrico BSPP con O-ring**
- Hexagonal male plug parallel BSPP with O-ring
- Stopfen zylindrisches Gewinde mit O-ring
- Bouchon à 6 pans mâle, cylindrique, BSPP-métrique, avec o-ring
- Tapón macho cilíndrico, BSPP-métrico, con o-ring

CODICE/CODE	F"	I	H	CH	PEZZI/PIECES
AS57OR18E	G1/8	6,5	10,5	14	10
AS57OR14E	G1/4	8	12,5	17	10
AS57OR38E	G3/8	9	13,5	20	10
AS57OR12E	G1/2	10	15,5	24	10

AS 57OR

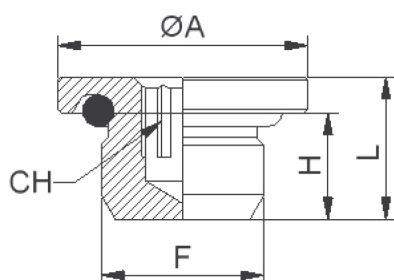

- Tappo con O-ring, esagono interno, cilindrico BSPP-metrico**
- Male plug with O-ring, hexagonal inside, parallel BSPP-metric
- Stopfen zylindrisches-metrisches Gewinde mit O-Ring
- Bouchon à 6 pans creux, cylindrique, BSPP-métrique
- Tapón macho cilíndrico hexágono interior, BSPP-métrico

CODICE/CODE	F"	H	L	ØA	CH	PEZZI/PIECES
AS57ORM5	M5	4	6,5	8	2,5	10
AS57OR18	G1/8	5,5	8,5	14	5	10
AS57OR14	G1/4	8	11,5	17	6	10
AS57OR38	G3/8	9	12,5	20	8	10
AS57OR12	G1/2	10	14	26	10	10

AS 57K

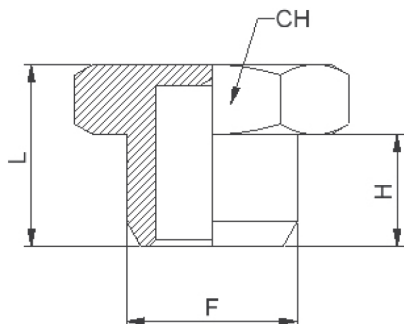

🇮🇹 Tappo esagonale conico BSPT

🇬🇧 Hexagonal male plug taper BSPT

🇩🇪 Stopfen konisches Gewinde

🇫🇷 Bouchon à 6 pans mâle, cónique BSPT

🇪🇸 Tapón macho cónico BSPT

CODICE/CODE	F"	H	L	CH	PEZZI/PIECES
AS57K0018	R1/8	7,5	11,5	10	10
AS57K0014	R1/4	11	15,5	14	10
AS57K0038	R3/8	11	16	17	10
AS57K0012	R1/2	12	17,5	22	10
AS57K0034	R3/4	15	21	27	10
AS57K0001	R1	15,5	22	34	10

AS 57B

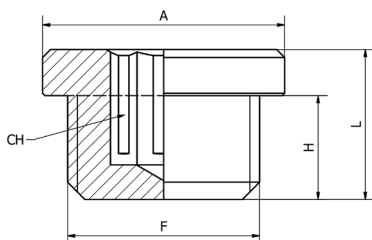

🇮🇹 Tappo senza O-ring, esagono interno, cilindrico BSPP-metrico

🇬🇧 Male plug without O-ring, hexagonal inside, parallel BSPP-metric

🇩🇪 Stopfen zylindrisches-metrisches Gewinde ohne O-Ring

🇫🇷 Bouchon à 6 pans creux, cylindrique BSPP-métrique

🇪🇸 Tapón macho cilíndrico hexágono interior BSPP-métrico

CODICE/CODE	F	L	H	A	CH	PEZZI/PIECES
AS57B00M5	M5	6,5	4	8	2,5	10
AS57B0018	1/8	9,5	6	15	5	10
AS57B0014	1/4	11,5	8	18	6	10
AS57B0038	3/8	13	9	21	8	10
AS57B0012	1/2	14,5	10	25	10	10
AS57B0034	3/4	15,5	11	31	14	10
AS57B0001	1"	19	13	38	17	5

AS 58

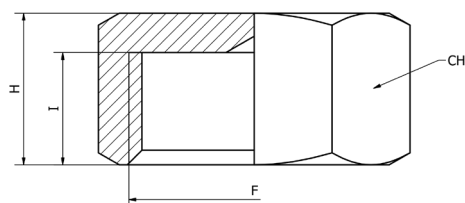
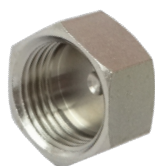

🇮🇹 Tappo femmina cilindrico BSPP-metrico

🇬🇧 Female plug parallel BSPP-metric

🇩🇪 Stopfen zylindrisches-metrisches Gewinde

🇫🇷 Bouchon femelle cylindrique BSPP-métrique

🇪🇸 Tapón hembra cilíndrico BSPP-métrico

CODICE/CODE	F"	I	H	CH	PEZZI/PIECES
AS5800M5	M5	5,5	7	8	10
AS580018	G1/8	9	11	14	10
AS580014	G1/4	11	13	17	10
AS580038	G3/8	11	13,5	21	10
AS580012	G1/2	11	13,5	24	10
AS580034	G3/4	12,5	15	30	10
AS580001	G1	12,5	15	38	10

AS 79

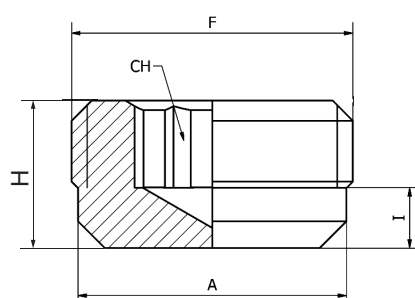

🇮🇹 Tappo a scomparsa cilindrico BSPP

🇬🇧 Hidden plug-parallel BSPP

🇩🇪 Stopfen zylindrisches Gewinde

🇫🇷 Bouchon, cylindrique BSPP

🇪🇸 Tapón macho cilíndrico BSPP

CODICE/CODE	F"	A	I	H	CH	PEZZI/PIECES
AS790018	G1/8	7,5	2	8	5	10
AS790014	G1/4	10	3	10	6	10
AS790038	G3/8	10	3,5	12	8	10
AS790012	G1/2	11	4	14	10	10

AS 79K

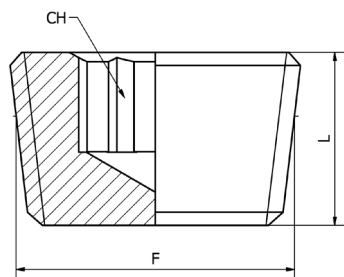

🇮🇹 Tappo a scomparsa conico BSPT

- 🇬🇧 Hidden plug-taper BSPT
- 🇩🇪 Stopfen konisches Gewinde
- 🇫🇷 Bouchon, conique BSPT
- 🇪🇸 Tapón macho cónico BSPT

CODICE/CODE	F"	L	CH	PEZZI/PIECES
AS79K0018	R1/8	7,5	5	10
AS79K0014	R1/4	10	6	10
AS79K0038	R3/8	10,5	8	10
AS79K0012	R1/2	13	10	10
AS79K0034	R3/4	15,5	14	10
AS79K0001	R1	17,5	17	10

AS 59

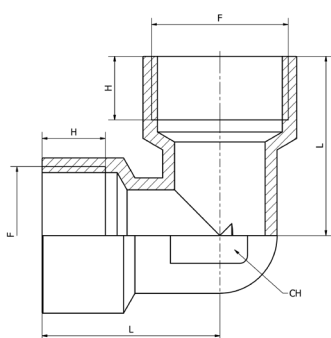

🇮🇹 Gomito femmina cilindrico BSPP

- 🇬🇧 Elbow female parallel BSPP
- 🇩🇪 Winkelstück zylindrisches Gewinde
- 🇫🇷 Equerre femelle cylindrique
- 🇪🇸 Racor a L hembra cilíndrico

CODICE/CODE	F"	H	L	CH	PEZZI/PIECES
AS5900M5	M5	4	11	9	10
AS590018	G1/8	8	21	10	10
AS590014	G1/4	11,5	25,5	13	10
AS590038	G3/8	11,5	28	17	10
AS590012	G1/2	14	33,5	21	10
AS590034	G3/4	16,5	36,5	25	10
AS590001	G1	19	45	30	10

AS 60K

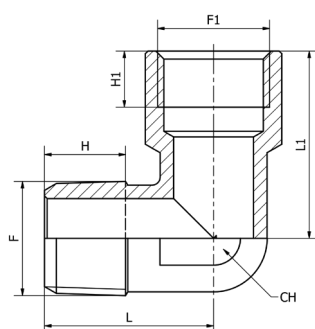

🇮🇹 Gomito maschio conico BSPT femmina cilindrico BSPP-metrico

- 🇬🇧 Elbow male taper BSPT female parallel BSPP-metric
- 🇩🇪 Winkelstück zylindrisches-konisches (metrisches) Gewinde
- 🇫🇷 Equerre mâle conique - femelle cylindrique BSPP-métrique
- 🇪🇸 Racor a L macho cónico - hembra cilíndrico BSPP-métrico

CODICE/CODE	F"	F1"	H	H1	L	L1	CH	PEZZI/PIECES
AS6000M5	M5	M5	4	5	11,5	11	9	10
AS60K0018	R1/8	G1/8	8	6	18,5	21	10	10
AS60K0014	R1/4	G1/4	11	8	24	26	13	10
AS60K0038	R3/8	G3/8	12	10	26,5	29	17	10
AS60K0012	R1/2	G1/2	14	14	31	33,5	21	10
AS60K0034	R3/4	G3/4	16	16,5	33	36,5	25	10
AS60K0001	R1	G1	17	19	39	45	30	10

AS 60

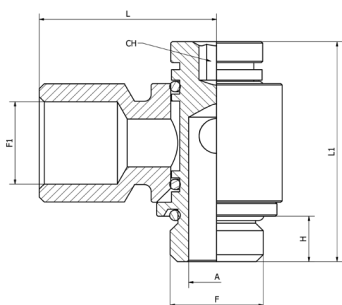

🇮🇹 Banjo singolo femmina girevole cilindrico BSPP

- 🇬🇧 Single banjo female rotating body parallel BSPP
- 🇩🇪 L Verschraubung drehbar zylindrisches Gewinde
- 🇫🇷 Raccord banjo femelle orientable cylindrique BSPP
- 🇪🇸 Racor banjo hembra orientable cilíndrico con tórica BSPP

CODICE/CODE	F"	F1"	H	ØA	L	L1	Chi	PEZZI/PIECES
AS601414	G1/4	G1/4	6,5	7,8	25	31,5	4	10

AS 61

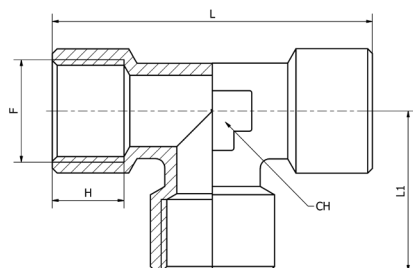

- T femmina cilindrico BSPP**
- T female parallel BSPP
- T Stück zylindrisches Gewinde
- Té égal femelle cylindrique BSPP
- Racor a T hembra cilíndrico BSPP

CODICE/CODE	F"	H	L	L1	CH	PEZZI/PIECES
AS6100M5	M5	5	22	11	9	10
AS610018	G1/8	8	42	21	10	10
AS610014	G1/4	11	51	25,5	13	10
AS610038	G3/8	11,5	56	28	17	10
AS610012	G1/2	14	67	33,5	21	10
AS610034	G3/4	16,5	73	36,5	25	10
AS610001	G1	19	90	45	30	10

AS 62K

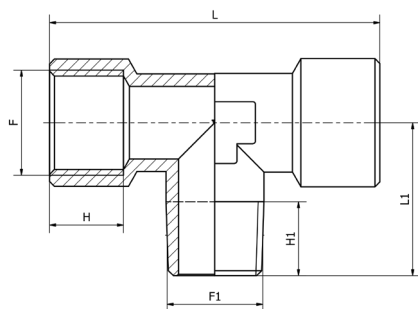

- T centrale conico BSPT-metrico**
- T central male taper BSPT-metric
- T Stück konisches-metrisches Gewinde
- Té égal femelle, centre mâle conique, métrique
- Racor a T macho central cónico, métrico

CODICE/CODE	F"	F1"	H	H1	L	L1	CH	PEZZI/PIECES
AS6200M5	M5	M5	5	4	22	11,5	9	10
AS62K0018	G1/8	R1/8	8	8	42	18,5	10	10
AS62K0014	G1/4	R1/4	8	11	51	23,5	13	10
AS62K0038	G3/8	R3/8	11,5	11,5	56	26	17	10
AS62K0012	G1/2	R1/2	14	14	67	31	21	10
AS62K0034	G3/4	R3/4	16,5	16	73	33	25	10
AS62K0001	G1	R1	19	17,5	90	39	30	10

AS 63K

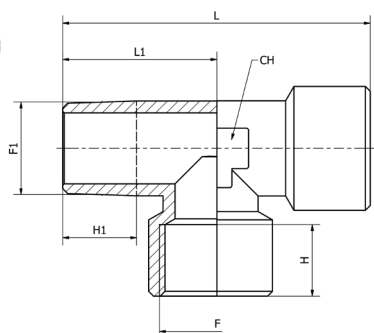

- T laterale conico BSPT-metrico**
- Lateral T male taper BSPT-metric
- T Stück konisches-metrisches Gewinde
- Té égal femelle, en bout mâle, conique, métrique
- Racor a T macho lateral cónico, métrico

CODICE/CODE	F"	F1"	H	H1	L	L1	CH	PEZZI/PIECES
AS6300M5	M5	M5	5	4	22,5	12	9	10
AS63K0018	G1/8	R1/8	8	8	39,5	18,5	10	10
AS63K0014	G1/4	R1/4	8	11,5	50	24	13	10
AS63K0038	G3/8	R3/8	8,5	11,5	54	26,5	17	10
AS63K0012	G1/2	R1/2	14	14	64,5	31	21	10
AS63K0034	G3/4	R3/4	16,5	16	69,5	33	25	10
AS63K0001	G1	R1	19	17,5	84	39	30	10

AS 64

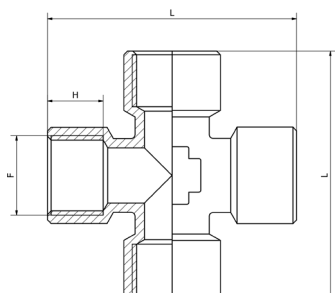

- Croce femmina cilindrico BSPP**
- Female cross parallel BSPP
- Kreuzstück konisches-metrisches Gewinde
- Croix égale femelle cylindrique BSPP
- Racor a cruz hembra cilíndrico BSPP

CODICE/CODE	F"	H	L	CH	PEZZI/PIECES
AS640018	G1/8	8	42	10	10
AS640014	G1/4	11	51	13	10
AS640038	G3/8	11,5	56	17	10
AS640012	G1/2	14	67	21	10

AS 65K

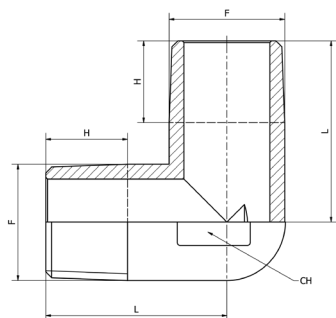

- Gomito maschio conico BSPT-metrico**
- Elbow male taper BSPT-metric**
- Winkelstück konisches-metrisches Gewinde**
- Equerre mâle, conique BSPT- métrique**
- Racor a L macho cónico BSPT- métrico**

CODICE/CODE	F"	F1"	H	H1	L	L1	CH	PEZZI/PIECES
AS6500M5	M5	M5	4	4	11,5	11,5	9	10
AS65K0018	R1/8	R1/8	8	8	18,5	18,5	10	10
AS65K1418	R1/4	R1/8	11	8	21,5	18,5	10	10
AS65K0014	R1/4	R1/4	11,5	11,5	24	24	13	10
AS65K0038	R3/8	R3/8	11,5	11,5	26	26	17	10
AS65K0012	R1/2	R1/2	14	14	31	31	21	10
AS65K0034	R3/4	R3/4	16	16	33	33	25	10
AS65K0001	R1	R1	17	17	39	39	30	10

AS 66K

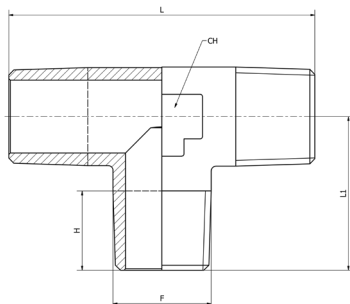

- T maschio conico BSPT-metrico**
- T male taper BSPT-metric**
- T Stück konisches-metrisches Gewinde**
- Té à piquage latéral, mâle, conique BSPT- métrique**
- Racor a T orientable macho lateral cónico BSPT- métrico**

CODICE/CODE	F"	H	L	L1	CH	PEZZI/PIECES
AS6600M5	M5	5	27,5	13,5	8	10
AS66K0018	R1/8	10,5	38	19	10	10
AS66K0014	R1/4	11	47	23,5	13	10
AS66K0038	R3/8	11,5	52	26	17	10
AS66K0012	R1/2	14	62	31	21	10
AS66K0034	R3/4	16	66,4	33	25	10
AS66K0001	R1	17,5	78	39	30	10

AS 67K

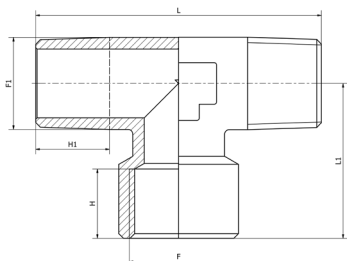

- T femmina doppio laterale conico BSPT-metrico**
- Double lateral female T taper BSPT-metric**
- T Stück Innengewinde konisches-metrisches Gewinde**
- Té égal femelle double, conique BSPT- métrique**
- Racor a T hembra doble, cónico BSPT- métrico**

CODICE/CODE	F"	F1"	H	H1	L	L1	CH	PEZZI/PIECES
AS6700M5	M5	M5	5,5	5	27,5	13	8	10
AS67K0018	G1/8	R1/8	8	8	37	21	10	10
AS67K0014	G1/4	R1/4	11	11	47	25,5	13	10
AS67K0038	G3/8	R3/8	11,5	11,5	52	28	17	10
AS67K0012	G1/2	R1/2	15	14	62	33,5	21	10
AS67K0034	G3/4	R3/4	16,5	16	66,4	36,5	25	10
AS67K0001	G1	R1	19	17,5	78	45	30	10

AS 68K

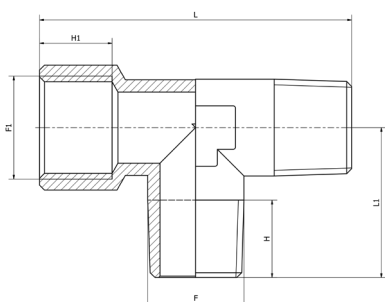

- T femmina laterale-centrale conico BSPT-metrico**
- Lateral-central female T taper BSPT-metric**
- T Stück konisches-metrisches Gewinde**
- Té égal femelle latéral-centre, conique BSPT- métrique**
- Racor a T hembra lateral-central, cónico BSPT- métrico**

CODICE/CODE	F"	F1"	H	H1	L	L1	CH	PEZZI/PIECES
AS6800M5	M5	M5	5	5,5	26	12	8	10
AS68K0018	R1/8	G1/8	8	8	39,5	18,5	10	10
AS68K0014	R1/4	G1/4	11,5	7,5	49	25	13	10
AS68K0038	R3/8	G3/8	11,5	11,5	54	26	17	10
AS68K0012	R1/2	G1/2	14	14	64,5	31	21	10
AS68K0034	R3/4	G3/4	16	16,5	69,5	33	25	10
AS68K0001	R1	G1	17,5	19	84	39	30	10

AS 69D

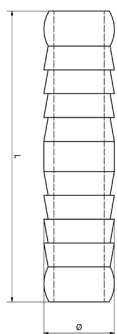

Portagomma a resca doppio

Double hose adapter

Schlauchtülle

Embout à douille annelée pour tube, double

Adaptador espiga, doble

CODICE/CODE	L	Ø	PEZZI/PIECES
AS69D0006	36	6	10
AS69D0008	44,5	8	10
AS69D0010	44,5	10	10

AS 69

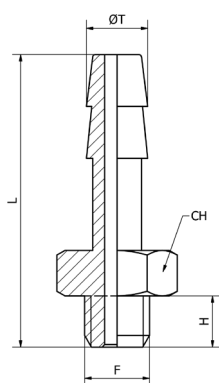

Portagomma maschio cilindrico BSPP-metrico

Hose male adapter parallel BSPP-metric

Schlauchtülle zylindrisches-metrisches Gewinde

Douille annelée, cylindrique BSPP-métrique

Espiga macho, cilíndrica BSPP-métrico

CODICE/CODE	ØT	F"	H	L	CH	PEZZI/PIECES
AS69M504	4,5	M5	4	22,5	8	10
AS691806	6	G1/8	6	29,5	12	10
AS691406	6	G1/4	8	32	14	10
AS691807	7	G1/8	6	29,5	12	10
AS691407	7	G1/4	8	32	14	10
AS691808	8	G1/8	6	29,5	12	10
AS691408	8	G1/4	8	32	14	10
AS693808	8	G3/8	9	33	19	10
AS691809	9	G1/8	6	29,5	12	10
AS691409	9	G1/4	8	32	14	10
AS693809	9	G3/8	9	33	19	10
AS691810	10	G1/8	6	30,5	12	10
AS691410	10	G1/4	8	33	14	10
AS693810	10	G3/8	9	34	19	10
AS691412	12	G1/4	8	33	14	10
AS693812	12	G3/8	9	34	19	10
AS691212	12	G1/2	10	35,5	22	10
AS693814	14	G3/8	9	34	19	10
AS691214	14	G1/2	10	37,5	22	10
AS693817	17	G3/8	9	37	19	10
AS691217	17	G1/2	10	39,5	22	10
AS693418	18	G3/4	11	41,5	30	10
AS691220	20	G1/2	10	39,5	22	10
AS693420	20	G3/4	11	41,5	30	10

AS 69K

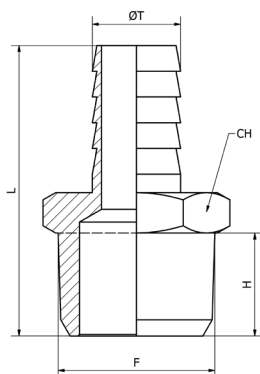

 **Portagomma maschio conico BSPT**

 Hose male adapter taper BSPT

 Schlauchtülle konisches Gewinde

 Douille annelée droit, conique BSPT

 Espiga recta macho cónica BSPT

CODICE/CODE	ØT	F"	H	L	CH	PEZZI/PIECES
AS69K1806	6	R1/8	8	31,5	12	10
AS69K1406	6	R1/4	11	35	14	10
AS69K1807	7	R1/8	8	31,5	12	10
AS69K1407	7	R1/4	11	35	14	10
AS69K1808	8	R1/8	8	31,5	12	10
AS69K1408	8	R1/4	11	35	14	10
AS69K1809	9	R1/8	8	31,5	12	10
AS69K1409	9	R1/4	11	35	14	10
AS69K3809	9	R3/8	11,5	35,5	17	10
AS69K1209	9	R1/2	14	38,5	22	10
AS69K1810	10	R1/8	8	32,5	12	10
AS69K1410	10	R1/4	11	36	14	10
AS69K3810	10	R3/8	11,5	36,5	17	10
AS69K1210	10	R1/2	14	39,5	22	10
AS69K1412	12	R1/4	11	36	14	10
AS69K3812	12	R3/8	11,5	36,5	17	10
AS69K1212	12	R1/2	14	39,5	22	10
AS69K3814	14	R3/8	11,5	38,5	17	10
AS69K1214	14	R1/2	14	41,5	22	10
AS69K3816	16	R3/8	11,5	38,5	17	10
AS69K1216	16	R1/2	14	41,5	22	10
AS69K3416	16	R3/4	16,5	45	27	10
AS69K3817	17	R3/8	11,5	40,5	18	10
AS69K1217	17	R1/2	14	43,5	22	10
AS69K3818	18	R3/8	11,5	40,5	19	10
AS69K1218	18	R1/2	14	43,5	22	10
AS69K3418	18	R3/4	16,5	47	27	10
AS69K3820	20	R3/8	11,5	41	22	10
AS69K1220	20	R1/2	14	43,5	22	10
AS69K3420	20	R3/4	16,5	46,5	27	10
AS69K3425	25	R3/4	16,5	53	27	10
AS69K0125	25	R 1	19	56	34	10

AS 69OR

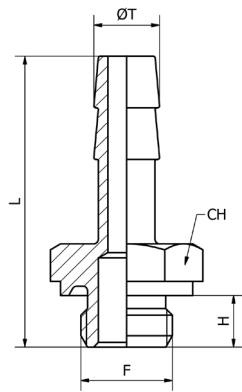

Portagomma maschio con O-ring cilindrico BSPP-metrico

Hose male adapter with O-ring parallel BSPP-metric

Schlauchtülle zylindrisches Gewinde mit O-Ring

Douille annelée, cylindrique BSPP-métrique avec o-ring

Espiga macho, cilíndrica BSPP-métrico con o-ring

CODICE/CODE	ØT	F"	H	L	CH	PEZZI/PIECES
AS69ORM545	4,5	M5	4,5	23	8	10
AS69OR1806	6	G1/8	6,5	30	14	10
AS69OR1406	6	G1/4	8	32	17	10
AS69OR3806	6	G3/8	9	33	20	10
AS69OR1807	7	G1/8	6,5	30	14	10
AS69OR1407	7	G1/4	8	32	17	10
AS69OR1808	8	G1/8	6,5	30	14	10
AS69OR1408	8	G1/4	8	32	17	10
AS69OR3808	8	G3/8	9	33	20	10
AS69OR1809	9	G1/8	6,5	30	14	10
AS69OR1409	9	G1/4	8	32	17	10
AS69OR3809	9	G3/8	9	33	20	10
AS69OR1810	10	G1/8	6	31,5	14	10
AS69OR1410	10	G1/4	8	34	17	10
AS69OR1412	12	G1/4	8	33	17	10
AS69OR3812	12	G3/8	9	34	20	10
AS69OR1212	12	G1/2	10	35,5	24	10
AS69OR3817	17	G3/8	9	38	20	10
AS69OR1217	17	G1/2	10	39,5	24	10

AS 69KL

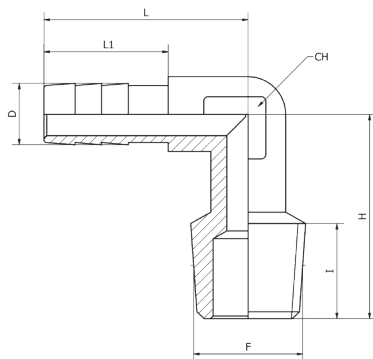

Gomito 90° portagomma maschio conico BSPT

Elbow 90° hose male adaptor taper

BSPT Winkelschlauchtülle 90° konisches Gewinde

Equerre mâle, conique BSPT

Racor a L macho cónico BSPT

CODICE/CODE	ØD	F"	I	H	L	L1	CH	PEZZI/PIECES
AS69KL1806A	6	R1/8	8	18,5	22,5	14	8	10
AS69KL1806B	6	R1/8	10	23	22,5	14	8	10
AS69KL1406	6	R1/4	11	23	23	14	9	10
AS69KL1807A	7	R1/8	8	18,5	22,5	14	8	10
AS69KL1807B	7	R1/8	10	23	22,5	14	8	10
AS69KL1407	7	R1/4	11	23	23	14	9	10

AS 93KL

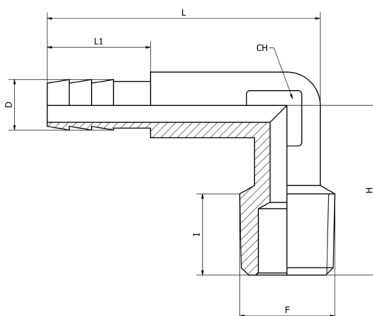

Gomito 90° portagomma maschio conico BSPT serie lunga

Elbow 90° hose male adaptor taper BSPT long serie

Winkelschlauchtülle 90° Lang konisches Gewinde

Equerre mâle, conique BSPT, long

Racor a L macho cónico BSPT, largo

CODICE/CODE	ØD	F"	I	H	L	L1	CH	PEZZI/PIECES
AS93KL1806A	6	R1/8	10	22	32,5	14	9	10
AS93KL1806B	6	R1/8	8	18,5	38	22	8	10
AS93KL1406A	6	R1/4	11	23	32,5	14	9	10
AS93KL1807A	7	R1/8	10	22	32,5	14	9	10
AS93KL1807B	7	R1/8	8	18,5	38	22	8	10
AS93KL1407B	7	R1/4	11	23	32,5	14	9	10

AS 94KL

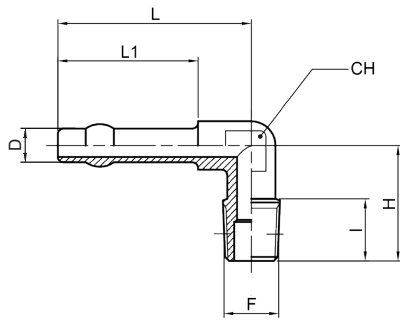

IT Gomito 90° portagomma maschio conico BSPT raggiato

UK Elbow 90° hose male adaptor taper BSPT

DE Winkelschlauchtülle 90° konisches Gewinde

FR Equerre mâle, conique BSPT

ES Racor a L macho cónico BSPT

CODICE/CODE	ØD	F"	I	H	L	L1	CH	PEZZI/PIECES
AS94KL1806	6	R1/8	11	20,5	34,5	25	9	10
AS94KL1807	7	R1/8	11	20,5	34,5	25	9	10
AS94KL1406	6	R1/4						10
AS94KL1407	7	R1/4						10

AS 95KL

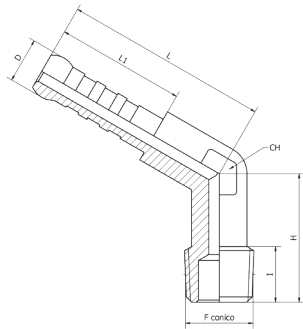

IT Gomito 120° portagomma maschio conico BSPT raggiato

UK Elbow 120° hose male adaptor taper BSPT

DE Winkelschlauchtülle 120° konisches Gewinde

FR Equerre 120°mâle, conique BSPT

ES Racor 120° macho cónico BSPT

CODICE/CODE	ØD	F"	I	H	L	L1	CH	PEZZI/PIECES
AS95KL1806	6	R1/8	8	18,5	29,5	20	8	10
AS95KL1807	7	R1/8	8	18,5	29,5	20	8	10

AS 96KL

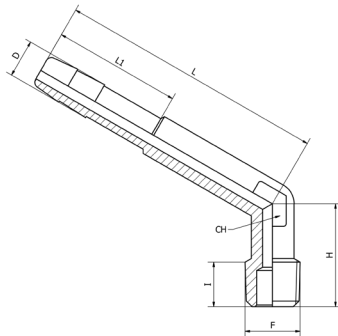

IT Gomito 120° portagomma maschio conico BSPT serie lunga

UK Elbow 120° hose male adaptor taper BSPT long serie

DE Winkelschlauchtülle 120° Lang konisches Gewinde

FR Equerre 120°mâle, conique BSPT, long

ES Racor 120° macho cónico BSPT, largo

CODICE/CODE	ØD	F"	I	H	L	L1	CH	PEZZI/PIECES
AS96KL1806	6	R1/8	8	18,5	38	23	8	10
AS96KL1807	7	R1/8	8	18,5	38	23	8	10

AS 97F

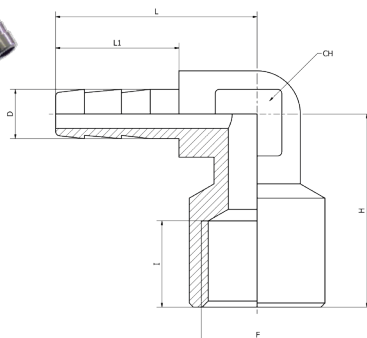

IT Gomito 90° portagomma femmina

UK Elbow 90° hose female adaptor

DE Winkelschlauchtülle 90° Lang

FR Equerre femelle

ES Racor a L hembra

CODICE/CODE	ØD	F	I	H	L	L1	CH	PEZZI/PIECES
AS97F1806	6	1/8	8	22	22	13	9	10
AS97F1406	6	1/4	11	23,5	24	13	13	10
AS97F1807	7	1/8	8	22	24	13	9	10
AS97F1407	7	1/4	11	23,5	24	13	13	10

AS 98F

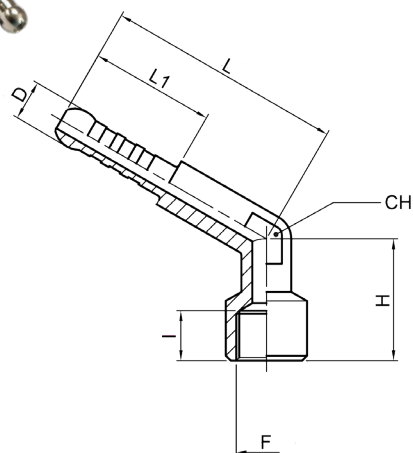

Gomito 120° portagomma femmina raggiato

Elbow 120° hose female adaptor

Winkelschlauchtülle 120° Lang

Equerre 120° femelle

Racor 120° hembra

CODICE/CODE	ØD	F	I	H	L	L1	CH	PEZZI/PIECES
AS98F1806	6	1/8	8	19,5	38	20	8	10
AS98F1807	7	1/8	8	19,5	38	20	8	10

AS 70K

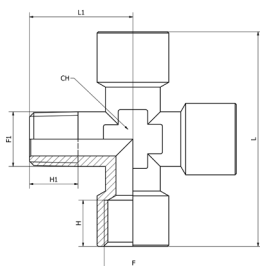

Croce 3 femmine 1 maschio conico BSPT

Cross 3 female 1 male taper BSPT

Kreuzstück konisches Gewinde

Croix égale mâle/femelle, conique BSPT

Racor a cruz macho-hembra, cónica BSPT

CODICE/CODE	F"	F1"	H	H1	L	L1	CH	PEZZI/PIECES
AS70K0018	G1/8	R1/8	8	8	42	18,5	10	10
AS70K0014	G1/4	R1/4	11	11	51	23,5	13	10
AS70K0038	G3/8	R3/8	11,5	11,5	56	26	17	10
AS70K0012	G1/2	R1/2	14	14	67	31	21	10

AS 71K

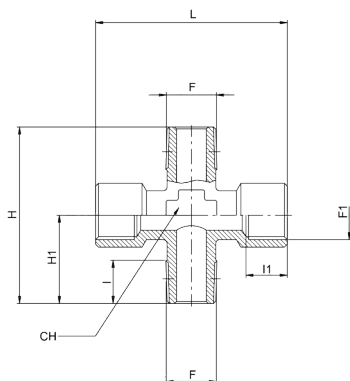

Croce 2 femmine 2 maschi conico BSPT

Cross 2 female 2 males taper BSPT

Kreuzstück konisches Gewinde





Croix 2 mâle 2 femelle, conique BSPT

Racor a cruz 2 macho 2 hembra, cónica BSPT

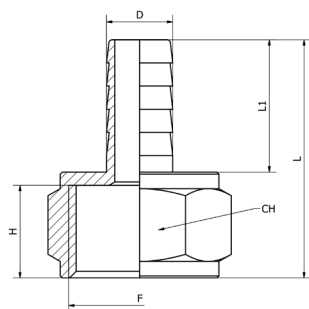
CODICE/CODE	F"	F1"	I	I1	H	H1	L	CH	PEZZI/PIECES
AS71K0014	1/4	1/4	11	11	47	23,5	51	13	10

AS 72





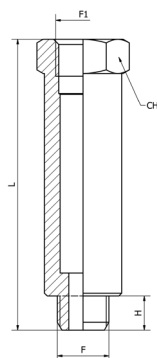

-  **Portagomma femmina cilindrico BSPP**
-  **Hose female adapter parallel BSPP**
-  **Schlauchtülle Innengewinde zylindrisches Gewinde**
-  **Douille annelée femelle cylindrique BSPP**
-  **Espiga hembra cilíndrico BSPP**

CODICE/CODE	Ø D	F"	H	L	L1	CH	PEZZI/PIECES
AS721806	6	G1/8	8	28,5	19	12	10
AS721406	6	G1/4	11	31,5	19	15	10
AS721807	7	G1/8	8	28,5	19	12	10
AS721407	7	G1/4	11	31,5	19	15	10
AS721808	8	G1/8	8	28,5	19	12	10
AS721408	8	G1/4	7,5	31,5	19	15	10
AS723808	8	G3/8	10	34,5	19,5	19	10
AS721208	8	G1/2	10	32,5	19	24	10
AS721809	9	G1/8	8	28,5	19	12	10
AS721409	9	G1/4	11	31,5	19	15	10
AS723809	9	G3/8	11,5	32	19	19	10
AS721810	10	G1/8	8	29,5	20	12	10
AS721410	10	G1/4	11	32,5	20	15	10
AS723810	10	G3/8	11,5	33	20	19	10
AS721210	10	G1/2	14	36	20	24	10
AS721412	12	G1/4	11	32,5	20	15	10
AS723812	12	G3/8	11,5	33	20	19	10
AS721212	12	G1/2	14	36	20	24	10
AS723814	14	G3/8	11,5	35	22	19	10
AS721214	14	G1/2	14	38	22	24	10
AS723816	16	G3/8	11,5	35	22	19	10
AS721216	16	G1/2	14	38	22	24	10
AS723817	17	G3/8	11,5	37	24	19	10
AS721217	17	G1/2	14	40	24	24	10
AS721218	18	G1/2	14	40	24	24	10
AS723418	18	G3/4	15	41,5	24	29	10
AS721220	20	G1/2	14	40,5	23	24	10
AS723420	20	G3/4	15	41,5	24	29	10
AS723425	25	G3/4	15	47,5	30	29	10

AS 73



-  **Prolunga cilindrico BSPP**
-  **Extension parallel BSPP**
-  **Verlängerung zylindrisches Gewinde**
-  **Rallonge égale, cylindrique BSPP**
-  **Prolongación cilíndrica BSPP**

CODICE/CODE	F"	F1"	H	L	CH	PEZZI/PIECES
AS731822	G1/8	G1/8	6	22	14	10
AS731832	G1/8	G1/8	7	32	14	10
AS731842	G1/8	G1/8	6	42	14	10
AS731851	G1/8	G1/8	6	51	14	10
AS731428	G1/4	G1/4	8	28	17	10
AS731435	G1/4	G1/4	8	35	17	10
AS731451	G1/4	G1/4	8	51	17	10
AS733841	G3/8	G3/8	9	41	22	10
AS731236	G1/2	G1/2	10	36	24	10
AS733450	G3/4	G3/4	12	50	30	10
AS730150	G1	G1	12	50	38	10

AS 75K

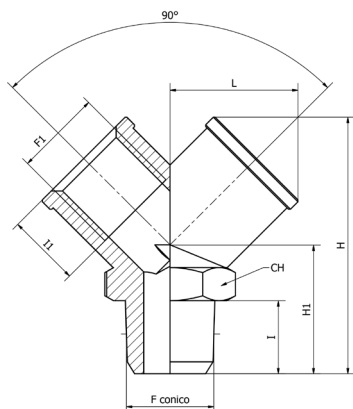

Y maschio conico BSPT

Y male taper BSPT

Y Verteiler Außengewinde konisches Gewinde

Y simple mâle, conique BSPT

Racor a Y macho cónico con tórica BSPT

CODICE/CODE	F"	F1"	I	I1	H1	L	H	CH	PEZZI/PIECES
AS75K0018	R1/8	G1/8	8	8	16	14,5	32	13	10
AS75K0014	R1/4	G1/4	11	11	20	18	38	17	10
AS75K0038	R3/8	G3/8	11,5	11,5	22	20,5	42,5	20	10
AS75K0012	R1/2	G1/2	14	14	27	26,5	53	25	10

AS 76

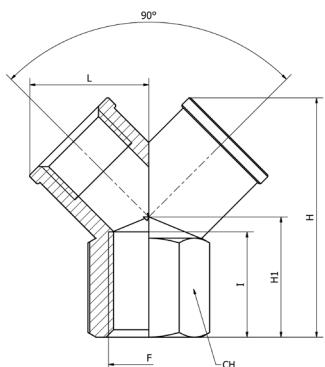

Y femmina cilindrico BSPP

Y female parallel BSPP

Y Verteiler Innengewinde

Y simple femelle, cylindrique BSPP

Racor a y hembra cónica con tórica BSPP

CODICE/CODE	F"	I	H1	L	H	CH	PEZZI/PIECES
AS760018	G1/8	8	12	14,5	26,5	13	10
AS760014	G1/4	11	14	18	32	17	10
AS760038	G3/8	11,5	16	20,5	37	20	10
AS760012	G1/2	14	19	26,5	45	25	10

AS 77

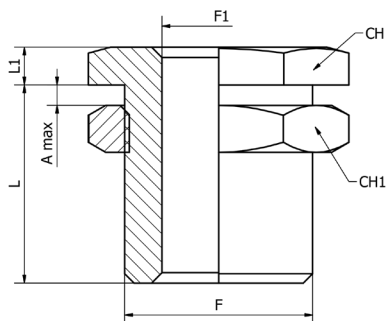

Diritto femmina passalamiera cilindrico BSPP-metrico

Straight female bulkhead parallel BSPP -metric

Schottverschraubung

Traversée de cloison cylindrique BSPP-métrique

Racor pasatabiques cilíndrico BSPP-métrico

CODICE/CODE	F"	F1"	A max	L	L1	CH	CH1	PEZZI/PIECES
AS7700M5	M10x1	M5	7	10,5	3,5	14	14	10
AS770018	M16x1.5	G1/8	10	14	4	19	22	10
AS770014	M20x1.5	G1/4	16	21	4	24	27	10
AS770038	M26x1.5	G3/8	15	21	5	30	32	10
AS770012	M28x1.5	G1/2	21	27	6	32	36	10

AS 80K

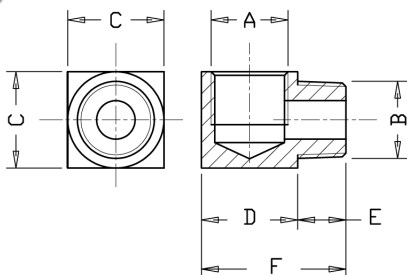

- L maschio conico BSPT femmina cilindrico BSPP-metrico**
- Elbow male taper BSPT female parallel BSPP-metric
- Winkelverschraubung konisches Gewindeisch/zyllindrisch-metrisch
- Raccord L mâle / femelle
- Racor a L macho-hembra

CODICE/CODE	A"	B"	C	D	E	F	PEZZI/PIECES
AS80M5M5	M5	M5	9	9	4,6	13,6	10
AS80K1818	G1/8	R1/8	14	14	8	22	10
AS80K1814	G1/8	R1/4	18	18	8	26	10
AS80K1418	G1/4	R1/8	18	18	10	28	10
AS80K1414	G1/4	R1/4	18	18	10	28	10
AS80K1438	G1/4	R3/8	20	21	10	31	10
AS80K3814	G3/8	R1/4	20	21	11	32	10
AS80K3838	G3/8	R3/8	20	21	11	32	10

AS 81K

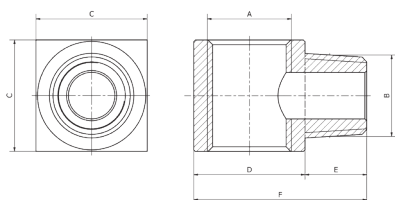

- T maschio conico BSPT femmina cilindrico BSPP-metrico**
- T male taper BSPT female parallel BSPP-metric
- T-Stück konisches Gewindeisch/zyllindrisch-metrisch
- Raccord té mâle / femelle
- Racor a T macho-hembra

CODICE/CODE	A"	B"	C	D	E	F	PEZZI/PIECES
AS81M5M5	M5	M5	9	9	4,6	13,6	10
AS81K1818	G1/8	R1/8	14	14	9	22	10
AS81K1414	G1/4	R1/4	18	18	10	28	10
AS81K3838	G3/8	R3/8	20	21	11	32	10

AS 82K

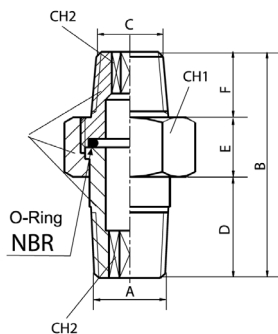

- Raccordo a 3 pezzi conico BSPT**
- Three pieces union taper BSPT
- Doppelnippel lösbar konisches Gewinde
- Raccord 3 pièces conique BSPT
- Racor 3 piezas cónico BSPT

CODICE/CODE	A"	B	C"	D	E	F	CH1	CH2	PEZZI/PIECES
AS82K1818	R1/8	33	R1/8	15	8,5	9,5	15	5	10
AS82K1814	R1/8	34	R1/4	15	8,5	10,5	15	5	10
AS82K1414	R1/4	38	R1/4	17	10	11	19	6	10
AS82K1438	R1/4	40	R3/8	17	10	13	19	6	10
AS82K3838	R3/8	52	R3/8	23	16	13	26	10	10
AS82K3812	R3/8	53	R1/2	23	16	14	26	10	10
AS82K1212	R1/2	54	R1/2	24	16	14	30	12	10

AS 83KG

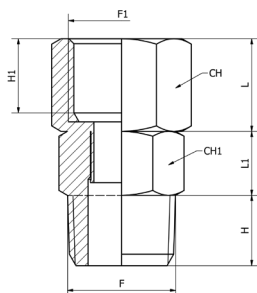

- Nipplo conico girevole**
- Nipple taper (rotating body)
- Doppelnippel drehbar konisches Gewinde
- Mamelon double conique orientable
- Machón cónico orientable

CODICE/CODE	F	F1	L	H	H1	CH	CH1	PEZZI/PIECES
AS83KG1818	R1/8	G1/8	28	8	8	12	13	10
AS83KG1414	R1/4	G1/4	34	11	11	14	16	10
AS83KG3838	R3/8	G3/8	35,5	11,5	11,5	17	19	10

AS 83G

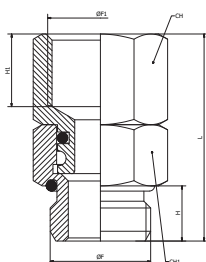

🇮🇹 Nipplo cilindrico girevole con O-Ring

- 🇬🇧 Nipple parallel (rotating body) with O-Ring
- 🇩🇪 Doppelnippel drehbar zylindrisches Gewinde mit O-Ring
- 🇫🇷 Mamelon double conique orientable avec O-ring
- 🇪🇸 Machón cónico orientable con O-ring

CODICE/CODE	F	F1	L	H	H1	CH	CH1	PEZZI/PIECES
AS83G1818	G1/8	G1/8	27	6,5	8	13	13	10
AS83G1414	G1/4	G1/4	32	8	11	16	16	10
AS83G3838	G3/8	G3/8	33,5	9	11,5	19	19	10

AS 87

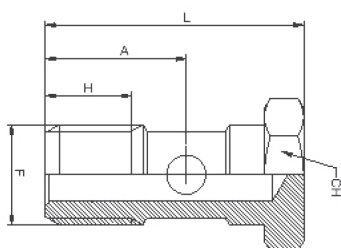

🇮🇹 Asta 1 posizione cilindrico BSPP-metrico

- 🇬🇧 Steam 1 position parallel BSPP-metric
- 🇩🇪 Drosselschraube einfach
- 🇫🇷 Vis une position cylindrique BSPP-métrique
- 🇪🇸 Tornillo una posición cilíndrico BSPP-métrico

CODICE/CODE	F"	A	H	L	CH	PEZZI/PIECES
AS8700M5	M5	9,5	6,5	18	8	10
AS870018	G1/8	15	9	27	14	10
AS870014	G1/4	16,5	11	29,5	17	10
AS870038	G3/8	17	12	31	19	10
AS870012	G1/2	24	16	42	27	10

Nota: Articolo da assemblare con RC 65 - RC 66 - RC 72

Note: Item to be assembled with RC 65 - RC 66 - RC 72

Hinweis: Zu montierender Artikel mit RC 65 - RC 66 - RC 72

Note: Article à assembler avec RC 65 - RC 66 - RC 72

Nota: Artículo que se ensamblará con RC 65 - RC 66 - RC 72

AS 88

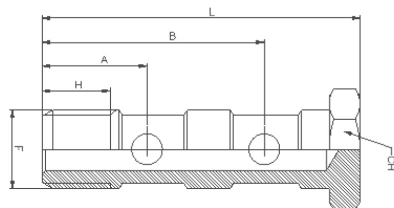

🇮🇹 Asta doppia cilindrico BSPP

- 🇬🇧 Steam 2 positions parallel BSPP
- 🇩🇪 Drosselschraube zweifach
- 🇫🇷 Vis double cylindrique BSPP
- 🇪🇸 Tornillo doble cilíndrico BSPP

CODICE/CODE	F"	H	A	B	L	CH	PEZZI/PIECES
AS880018	G1/8	9	15	31	44,5	14	10
AS880014	G1/4	11	17	36	51,5	17	10
AS880038	G3/8	12	20,5	42	58,6	22	10
AS880012	G1/2	14	24	50	68	27	10

Nota: Articolo da assemblare con RC 65 - RC 66 - RC 72

Note: Item to be assembled with RC 65 - RC 66 - RC 72

Hinweis: Zu montierender Artikel mit RC 65 - RC 66 - RC 72

Note: Article à assembler avec RC 65 - RC 66 - RC 72

Nota: Artículo que se ensamblará con RC 65 - RC 66 - RC 72

AS 87OR

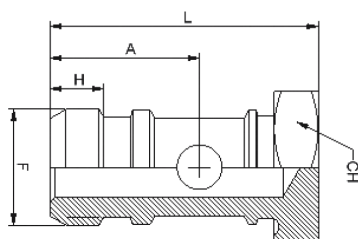

🇮🇹 Asta singola cilindrica BSPP con O-ring

- 🇬🇧 Steam single parallel BSPP with O-ring
- 🇩🇪 Drosselschraibe einfach mit O-Ring
- 🇫🇷 Vis unique cylindrique BSPP avec O-ring
- 🇪🇸 Tornillo solo cilíndrico BSPP con O-ring

CODICE/CODE	F"	H	A	L	CH	PEZZI/PIECES
AS87OR18	G1/8	4,5	13,75	25	14	10
AS87OR14	G1/4	6	16,7	30	17	10
AS87OR38	G3/8	6	18	34	22	10
AS87OR12	G1/2	7,4	21,5	39,5	27	10

Nota: Articolo da assemblare con RT 63 - RT 64 - RK 63 - RK 64

Note: Item to be assembled with RT 63 - RT 64 - RK 63 - RK 64

Hinweis: Zu montierender Artikel mit RT 63 - RT 64 - RK 63 - RK 64

Note: Article à assembler avec RT 63 - RT 64 - RK 63 - RK 64

Nota: Artículo que se ensamblará con RT 63 - RT 64 - RK 63 - RK 64

AS 88OR

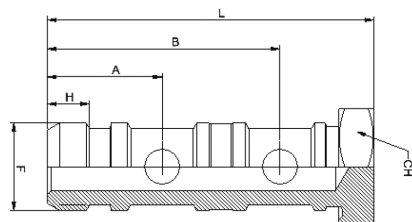

🇮🇹 Asta doppia cilindrica BSPP con O-ring

🇬🇧 Steam double parallel BSPP with O-ring

🇩🇪 Drosselschraibe zweifach mit O-Ring

🇫🇷 Vis double cylindrique BSPP avec O-ring

🇪🇸 Tornillo doble cilíndrico BSPP con O-ring

CODICE/CODE	F"	H	A	B	L	CH	PEZZI/PIECES
AS88OR18	G1/8	4,5	13	29	40	14	10
AS88OR14	G1/4	6	16,5	33,5	47	17	10
AS88OR38	G3/8	8,5	17	37,6	52,5	22	10
AS88OR12	G1/2	10,8	21	45	63	27	10

Nota: Articolo da assemblare con RT 63 - RT 64 - RK 63 - RK 64

Note: Item to be assembled with RT 63 - RT 64 - RK 63 - RK 64

Hinweis: Zu montierender Artikel mit RT 63 - RT 64 - RK 63 - RK 64

Note: Article à assembler avec RT 63 - RT 64 - RK 63 - RK 64

Nota: Artículo que se ensamblará con RT 63 - RT 64 - RK 63 - RK 64

AS 91

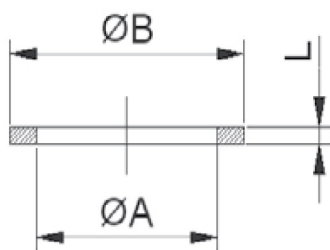

N = NYLON

🇮🇹 Rondelle in nylon/alluminio

🇬🇧 Washers in nylon/aluminum

🇩🇪 Dichtungen Nylon/Aluminium

🇫🇷 Joint en nylon/aluminium

🇪🇸 Arandela en nylon/aluminio

CODICE/CODE	ØA	ØB	L	PEZZI/PIECES
AS91N00M5	M5	8,5	1,5	100
AS91N0018	G1/8	14	1,5	100
AS91N0014	G1/4	18	1,5	100
AS91N0038	G3/8	21	1,5	100
AS91N0012	G1/2	26	1,5	100
AS91N0034	G3/4	26,7	2,5	100
AS910018	G1/8	14	1,5	100
AS910014	G1/4	17,3	1,5	100
AS910038	G3/8	21	1,5	100
AS910012	G1/2	26	1,5	100
AS910034	G3/4	34	1,5	100
AS910001	G1	41	1,5	100

AS 92N

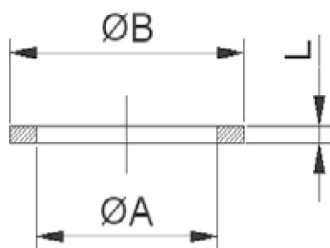

🇮🇹 Rondella in nylon dentellata

🇬🇧 Nylon washers serrated

🇩🇪 Dichtungen Nylon gezähnt

🇫🇷 Joint imperdable en nylon

🇪🇸 Arandela dentada en nylon

CODICE/CODE	ØA	ØB	L	PEZZI/PIECES
AS92N00M5	M5	8	1	100
AS92N0018	G1/8	14	1,5	100
AS92N0014	G1/4	18	1,5	100
AS92N0038	G3/8	21	1,5	100
AS92N0012	G1/2	26	1,5	100