



AUTOMATION

CILINDRI TONDI Ø32-63
ROUND CYLINDERS Ø32-63

SERIE

RA



MADE IN ITALY

CILINDRI TONDI Ø32-63 SERIE RA
ROUND CYLINDERS Ø32-63 RA SERIE



VERSIONI - VERSIONS

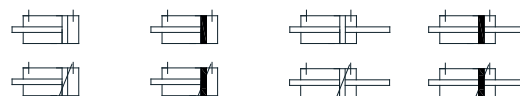

Materiali - Materials	
Testate - Covers	Alluminio anodizzato Anodized aluminum
Tubo - Tube	Acciaio inox AISI304 Stainless steel AISI304
Stelo - Piston rod	Acciaio inox AISI303 Stainless steel AISI303
Pistone - Piston	Alluminio Aluminum
Guarnizioni - Seals	Poliuretano Polyurethane
Boccola guida - Guiding bush	Bronzo sinterizzato Sintered bronze

Informazioni tecniche - Technical features	
Fluido - Fluid	Aria compressa filtrata lubrificata e non Filtered and lubricated or not compressed air
Temp. impiego Working Temp.	-35°C +80°C con aria secca / w dry air
Pressione MAX MAX pressure	10 bar

CHIAVE DI CODIFICA - KEY CODE

Base		Versioni - Versions					Ø	Corsa - Stroke		
RA	DE	Doppio effetto molla anteriore	0	Standard	M	Magnetico	A	Ammortizzato	032	0010
		Double acting front spring		Standard		Magnetic		Cushioned		
			1	Passante	N	Non magnetico	N	Non ammortizzato	050	...
				Through rod		Not magnetic		Not Cushioned		

CODICE ESEMPIO - SAMPLE CODE

RA	DE	0	M	N	063	0100	+	varianti	variants
----	----	---	---	---	-----	------	---	----------	----------

VARIANTI - VARIANTS

	Guarnizioni Seals	Materiale stelo Piston rod material	Filetto stelo speciale Special piston rod thread	Prolunga stelo Extended piston rod	Atex		
HR	Guarnizione stelo Viton	X	AISI316	Su richiesta	PXXX	xxx = mm	T
	Viton Rod seal			On request			
HA	Tutto Viton						
	All Viton						

CORSE STANDARD - STANDARD STROKES

Ø	10	25	50	80	100	125	160	200	250	300
32	°	°	°	°	°	°	°	°	°	°
40	°	°	°	°	°	°	°	°	°	°
50	°	°	°	°	°	°	°	°	°	°
63	°	°	°	°	°	°	°	°	°	°

FORZE TEORICHE - THEORETICAL FORCES

Forze teoriche a 6 bar - Theoretical forces at 6 bar

Ø	Forza di spinta (N) Thrust force (N)	Forza in trazione (N) Traction force (N)
32	482	414
40	754	633
50	1178	989
63	1869	1681

DOPPIO EFFETTO - DOUBLE ACTING

RADE0NN - RADE0MN

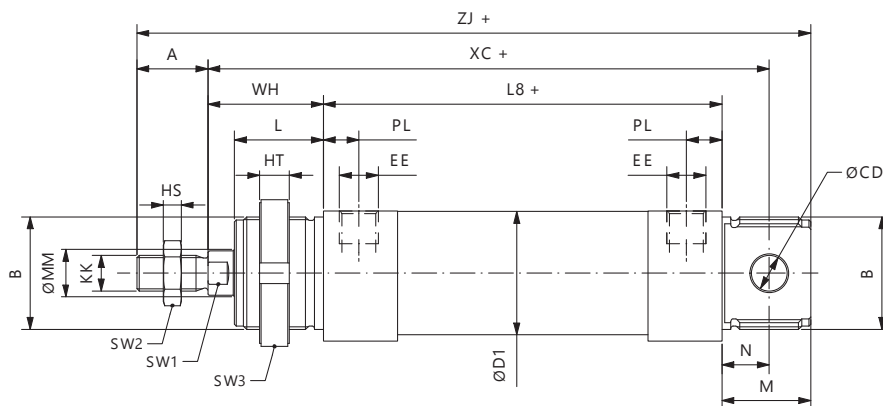
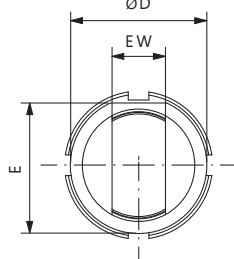

Ø	E	A	HS	B	L	ØCD	ØD1	ØD	EE	PL	EW	KK	HT	N	L8	ZJ	ØMM	SW1	SW2	SW3	WH	XC
32	36,5	22	6	M30X1,5	26	10	38	45	1/8G	9	16	M10X1,25	7	13	69,5	151,5	12	10	17	40	34	117,5
40	44	24	7	M38X1,5	30	12	46	50	1/4G	12	18	M12X1,25	8	15	84,6	177,6	16	13	19	46	39	139,6
50	55	32	8	M45X1,5	33	16	57	58	1/4G	12	21	M16X1,5	9	16	86,2	195,2	20	17	24	52	44	147,2
63	67,5	32	8	M45X1,5	33	16	70	58	3/8G	13	21	M16X1,5	9	16	94,2	204,2	20	17	24	52	45	156,2

+ = sommare corsa / plus stroke length
Ghiera non compresa nella fornitura / Cover nut not included

DOPPIO EFFETTO AMMORTIZZATO - DOUBLE ACTING CUSHIONED

RADE0NA - RADE0MA

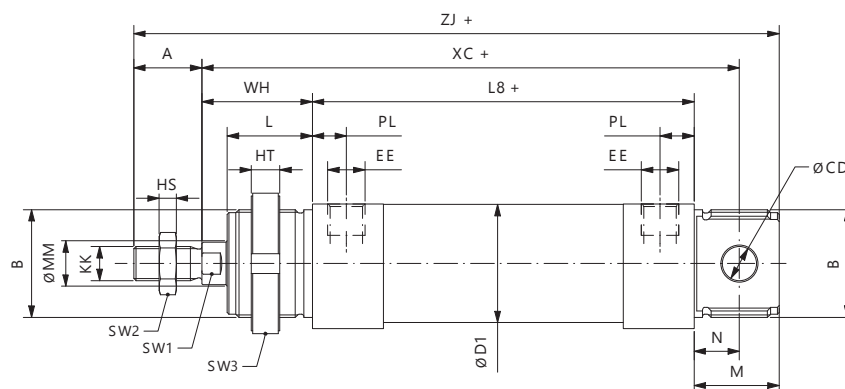
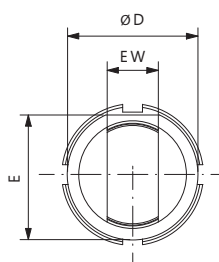

Ø	E	A	HS	B	L	ØCD	ØD1	ØD	EE	PL	EW	KK	HT	N	L8	ZJ	ØMM	SW1	SW2	SW3	WH
32	36,5	22	6	M30X1,5	26	10	38	45	1/8G	9	16	M10X1,25	7	13	69,5	151,5	12	10	17	40	34
40	44	24	7	M38X1,5	30	12	46	50	1/4G	12	18	M12X1,25	8	15	84,6	177,6	16	13	19	46	39
50	55	32	8	M45X1,5	33	16	57	58	1/4G	12	21	M16X1,5	9	16	86,2	195,2	20	17	24	52	44
63	67,5	32	8	M45X1,5	33	16	70	58	3/8G	13	21	M16X1,5	9	16	94,2	204,2	20	17	24	52	45

+ = sommare corsa / plus stroke length
Ghiera non compresa nella fornitura / Cover nut not included

DOPPIO EFFETTO PASSANTE - DOUBLE ACTING THROUGH ROD

RADE1NN - RADE1MN

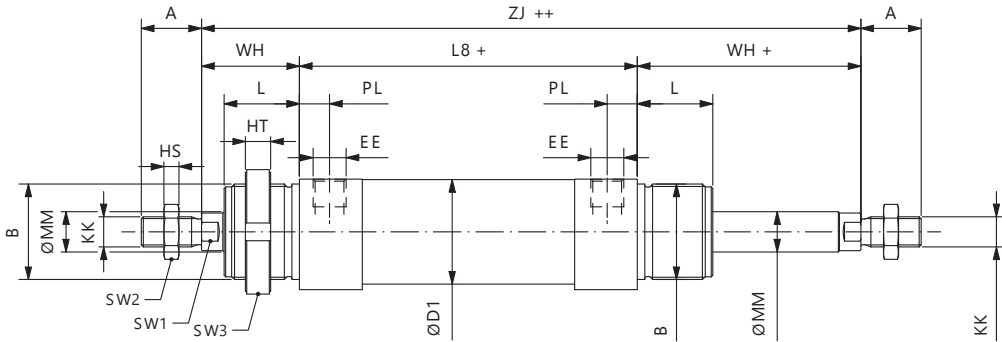
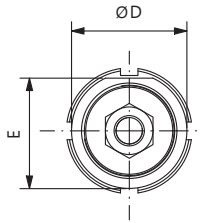

Ø	E	A	HS	B	L	ØD1	ØD	EE	PL	KK	HT	L8	ZJ	ØMM	SW1	SW2	SW3	WH
32	36,5	22	6	M30X1,5	26	38	45	1/8G	9	M10X1,25	7	69,5	137,5	12	10	17	40	34
40	44	24	7	M38X1,5	30	46	50	1/4G	12	M12X1,25	8	84,6	162,6	16	13	19	46	39
50	55	32	8	M45X1,5	33	57	58	1/4G	12	M16X1,5	9	86,2	174,2	20	17	24	52	44
63	67,5	32	8	M45X1,5	33	70	58	3/8G	13	M16X1,5	9	94,2	184,2	20	17	24	52	45

+ = sommare corsa / plus stroke length

++ = sommare 2 x corsa / plus stroke length x 2

Ghiera non compresa nella fornitura / Cover nut not included

DOPPIO EFFETTO AMMORTIZZATO PASSANTE - DOUBLE ACTING CUSHIONED THROUGH ROD

RADE1NA - RADE1MA

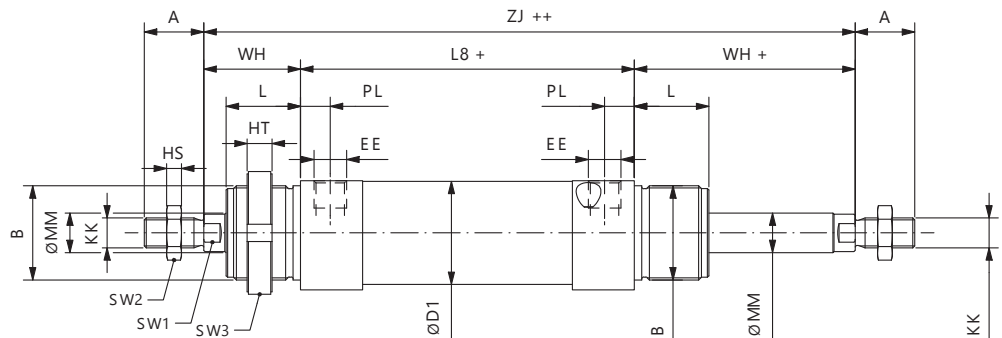
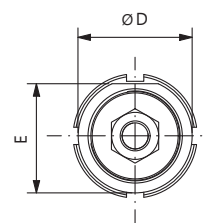

Ø	E	A	HS	B	L	ØD1	ØD	EE	PL	KK	HT	L8	ZJ	ØMM	SW1	SW2	SW3	WH
32	36,5	22	6	M30X1,5	26	38	45	1/8G	9	M10X1,25	7	69,5	137,5	12	10	17	40	34
40	44	24	7	M38X1,5	30	46	50	1/4G	12	M12X1,25	8	84,6	162,6	16	13	19	46	39
50	55	32	8	M45X1,5	33	57	58	1/4G	12	M16X1,5	9	86,2	174,2	20	17	24	52	44
63	67,5	32	8	M45X1,5	33	70	58	3/8G	13	M16X1,5	9	94,2	184,2	20	17	24	52	45

+ = sommare corsa / plus stroke length

++ = sommare 2 x corsa / plus stroke length x 2

Ghiera non compresa nella fornitura / Cover nut not included

ACCESSORI DI FISSAGGIO - MOUNTING ACCESSORIES

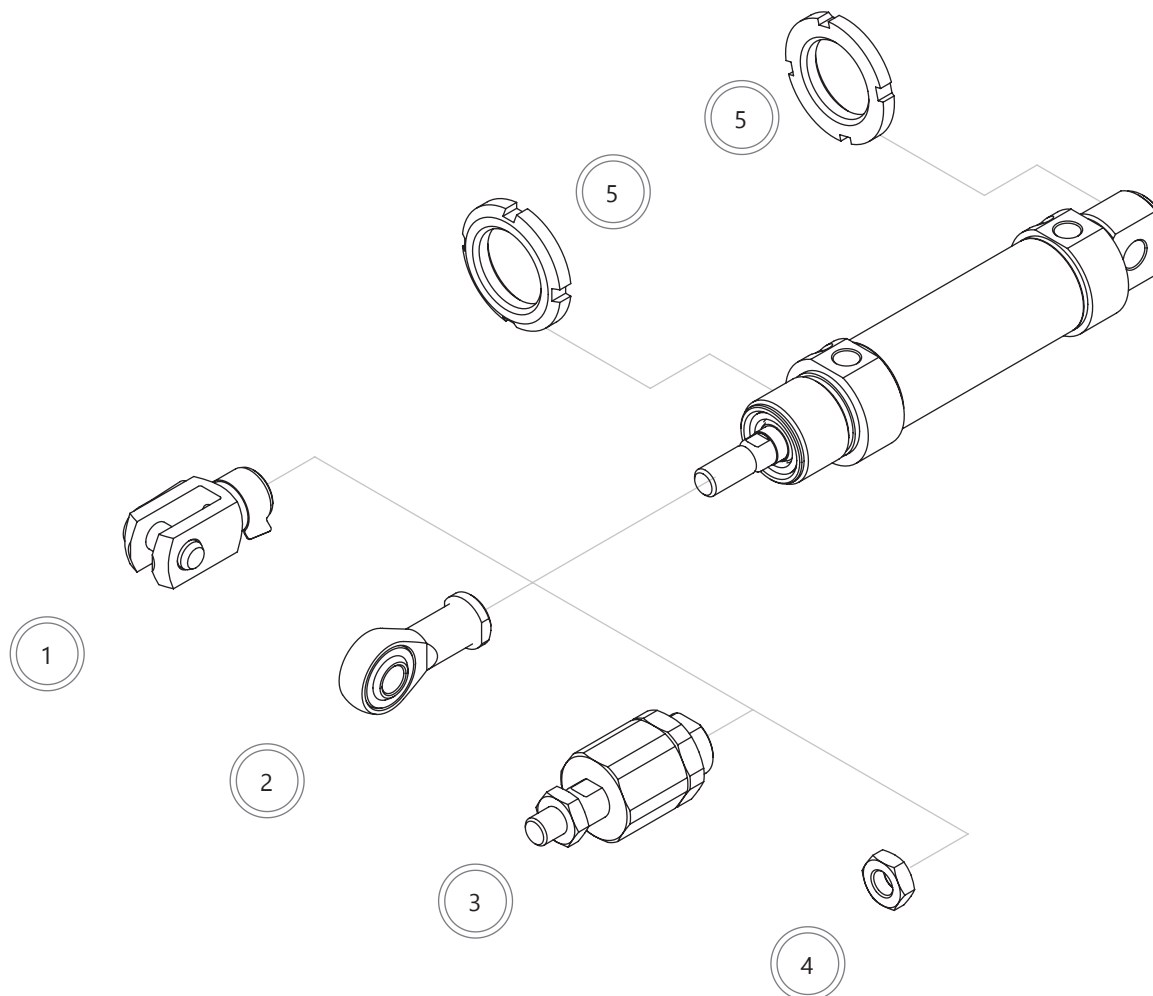

	Descrizione Description	Acciaio Steel	Acciaio inox Stainless steel
1	Forcella Clevis	152	177
2	Testa a snodo Rod end	153	177
3	Giunto autoallineante Self-aligning joint	153	-
4	Dado stelo Piston rod nut	154	178
5	Ghiera Slotted nut	155	178

KIT DI MONTAGGIO - MOUNTING KIT

Contenuto del Kit - Kit parts
Kit cilindro doppio effetto magnetico Kit for double acting magnetic cylinder
Testata anteriore completa / Complete front cover
Testata posteriore completa / Complete rear cover
Pistone completo / Complete piston
Dado stelo / Piston rod nut
Tappi protezione alimentazioni / Air supply protection caps
Dado testata / Cover nut
RADE0MNØK001

Kit disponibile anche nelle altre versioni.
Kit available also in other versions.

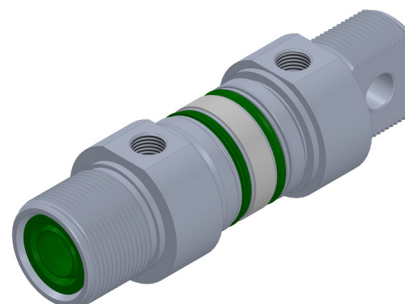

ASTA STELO - PISTON ROD BAR

Ø cilindro cylinder Ø	Barra stelo - Piston rod bar		Ø stelo Piston rod Ø
	Barra stelo in AISI303 AISI303 piston rod bar	Barra stelo in AISI316 AISI316 piston rod bar	
32	V30BRT0312000	V30BRT0512000	12
40	V30BRT0316000	V30BRT0516000	16
50	V30BRT0320000	V30BRT0520000	20
63	V30BRT0320000	V30BRT0520000	20

Barre lunghezza 3 metri
3 meter long bars



BARRA TUBO - TUBE BAR

Ø cilindro cylinder Ø	Barra tubo - Tube bar	
	Barra tubo in AISI304 AISI304 tube bar	
32	V30TGT0432000	Ø32XØ33,6
40	V30TGT0440000	Ø40XØ41,6
50	V30TGT0450000	Ø50XØ52,4
63	V30TGT0463000	Ø63XØ65,4

Barre lunghezza 3 metri
3 meter long bars

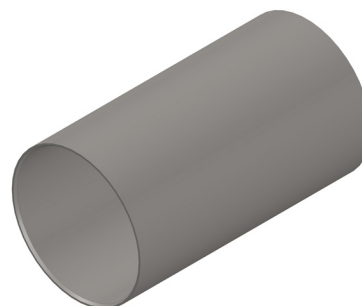

Barre tubo e barre stelo disponibili anche lavorate e tagliate a misura/corsa.
Tube bars and piston rod bars available also worked and cut at length/stroke.



MADE IN ITALY