

Belt driven guided linear unit

Linearantrieb mit Zahnriemen und integrierter Kugelumlaufführung
 Attuatori lineari a cinghia e guida a ricircolo di sfere

TECHNICAL DATA | TECHNISCHE DATEN | DATI TECNICI

Size - Baugröße - Taglia			55x55
Max. speed - Max. Geschwindigkeit - Velocità max		m/s	3
Max. stroke length - Max. Hub - Corsa max		mm	6700
Min. stroke length - Min. Hub - Corsa min		mm	100
Pulley drive ratio - Hub pro Umdrehung - Corsa/giro puleggia		mm	120
Number of teeth of pulley - Zähne der Riemenscheibe - nr. denti puleggia			24
Teeth belt with Steel Reinforced Polyurethane ATL 5 profile clearance 0, width 16 mm ATL 5-Profil Riemen 16 mm Breite 5mm Achsabstand Tipo di cinghia profilo ATL passo 5 larghezza 16 mm			
Max rpm - Max. Drehzahl der Antriebswelle - Max nr. di giri in ingresso		rpm	1500
Base weight - Gewicht bei 0mm Hub - Peso corsa 0 mm		Kg	4,8
Add for 100 mm of stroke - Gewicht bei 100mm Hub - Peso corsa 100 mm		Kg	0,63
Max. load* - Max. Belastung - Carico max*	Fx	N	820
	Fy	N	10800
	Fz	N	10800
Moments* - Max. Belastungsmoment* - Momenti max*	Mx	Nm	395
	My	Nm	480
	Mz	Nm	480
Inertia moment Aluminum profile - Flächenträgheitmoment - Momento d'inerzia profilo	Ix	cm4	36
	Iy	cm4	45
Repeatability - Wiederholgenauigkeit - Ripetibilità		mm	± 0,05
Max. radial load on input shaft - Max. axiallylasten an der Antriebswelle Carico assiale max all'albero motore		N	300
No load torque - Leerlaufmoment - Coppia resistente		Nm	>0,5

* Max values for dynamic conditions. Please refer to the following formula when combined loads are applied.

* Für die Ermittlung der maximalen dynamischen Tragzahlen bei kombinierten Kraftangriffspunkten, nutzen Sie bitte die nebenstehende Berechnungsformel.

* Valori massimi in condizioni dinamiche. In presenza di carichi combinati riferirsi alla formula per la verifica dei carichi massimi da applicare.

$$\frac{F_{yA}}{F_y} + \frac{F_{zA}}{F_z} + \frac{M_{xA}}{M_x} + \frac{M_{yA}}{M_y} + \frac{M_{zA}}{M_z} \leq 1$$

The A letters show the calculated value.
 Der A Parameter entspricht dem errechneten Wert.
 La lettera A indica i valori complessivi calcolati

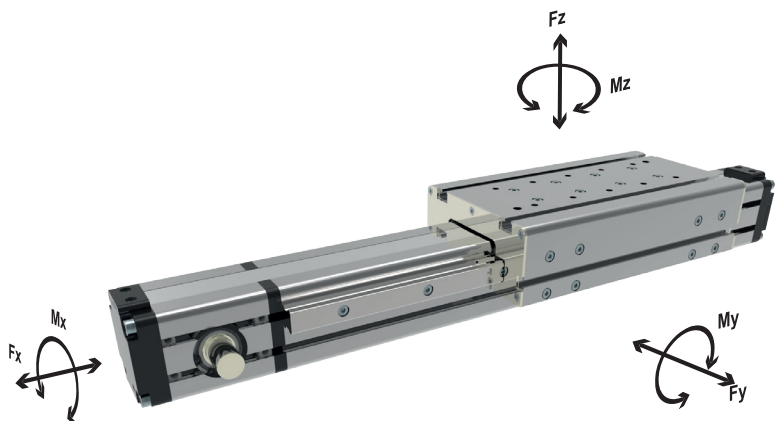

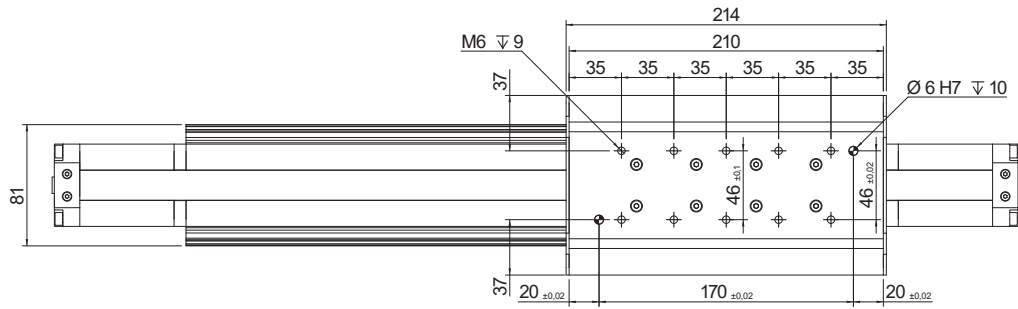
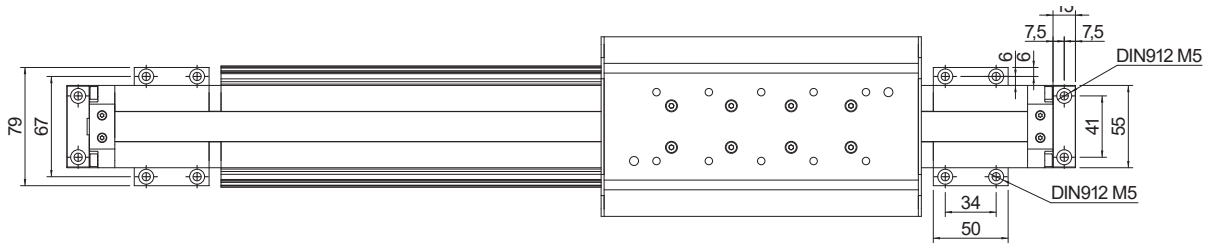

Corsa + 390,5
Stroke + 390,5
Hub + 390,5

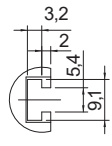
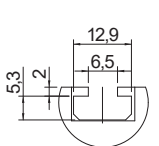
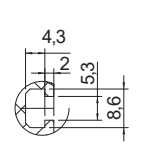
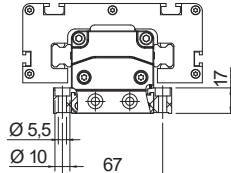
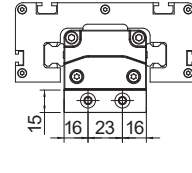
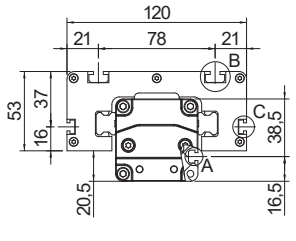
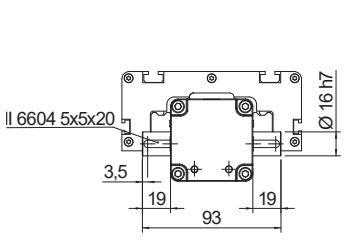
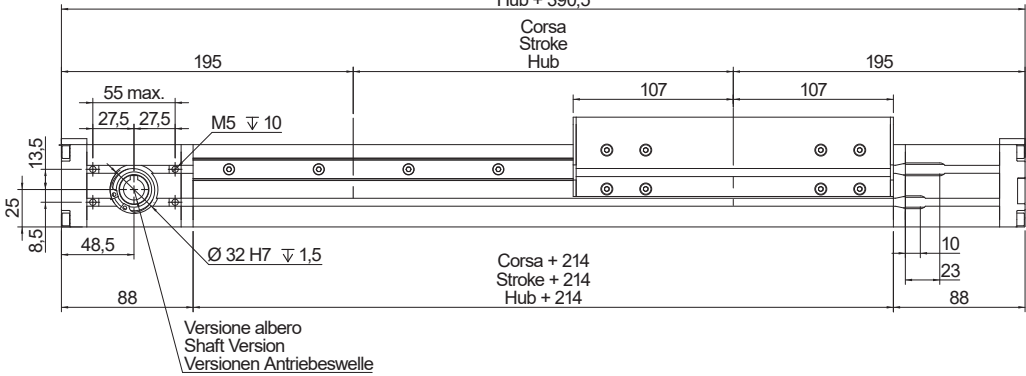

View A
Ansicht A
Vista A

View B
Ansicht B
Vista B

View C
Ansicht C
Vista C

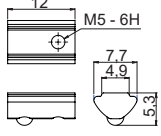
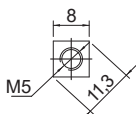

Left mount M6L
Antriebswelle links M6L
Lato sinistro M6L



Dual mount D6
Doppelwelle D6
Doppio albero D6

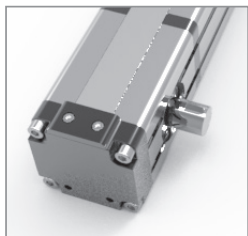

Right mount M6R
Antriebswelle rechts M6R
Lato destro M6R

Codice: DQM05
Part n.: DQM05
Bestellcode: DQM05

Codice: DTM05-M5
Part.n.: DTM05-M5
Bestellcode: DTM05-M5



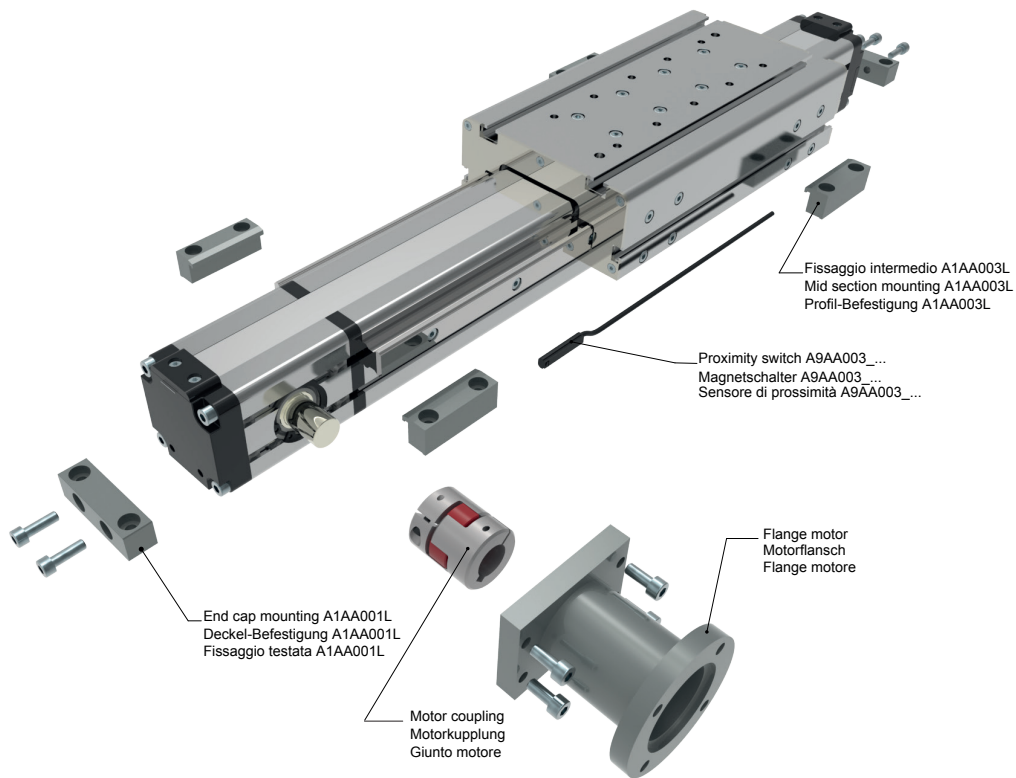

ORDERING INFORMATION | Bestallangaben Baureihe | Codici per l'ordinazione

¹Proximity switch A9AA003_... | ¹Magnetschalter A9AA003_... | ¹Sensore di prossimità A9AA003_...

Part nr. Ident nr. Cod.	Cable Kabel Cavo	Output Ausgangfunktion Uscita
A9AA003_01	with 2 mt cable mit 2 mt kabel con cavo 2 mt	PNP
A9AA003_02	with 2 mt cable mit 2 mt kabel con cavo 2 mt	NPN
A9AA003_03	200 mm with M8 plug in mit 200 mm kabel und M8 stecker 200 mm conn. M8	PNP
A9AA003_04	200 mm with M8 plug in mit 200 mm kabel und M8 stecker 200 mm conn. M8	NPN
A9AA003_NC	with 2 mt cable mit 2 mt kabel con cavo 2 mt	NC

MTS55 - 0900 - F2

Series and size 55x55
Serie und BaugöÙe 55x55
Serie e taglia 55x55

Stroke mm
Hub mm
Corsa mm

Shaft | Versionen Antriebeswelle | Versione Albero

- F2: Female shaft Ø12 mm with keyshaft
Hohlwelle mit Ø12 mm und Passfeder
Albero femmina Ø12 mm con chiavetta
- F4: Female shaft Ø14 mm with keyshaft
Hohlwelle mit Ø14 mm und Passfeder
Albero femmina Ø14 mm con chiavetta
- M6L: Male shaft Ø16 mm mount left
Außenwelle mit Ø16 mm und Wellenposition rechts
Albero maschio uscita Ø16 mm lato sinistro
- M6R: Male shaft Ø16 mm mount right
Außenwelle mit Ø16 mm und Wellenposition links
Albero maschio uscita Ø16 mm lato destro
- D6: Double male shaft Ø16 mm
Doppelwelle mit Ø16 mm
Doppio albero maschio Ø16 mm